

ENGINEERING GUIDE

# FN Fan-Coil Units High-Performance, Horizontal

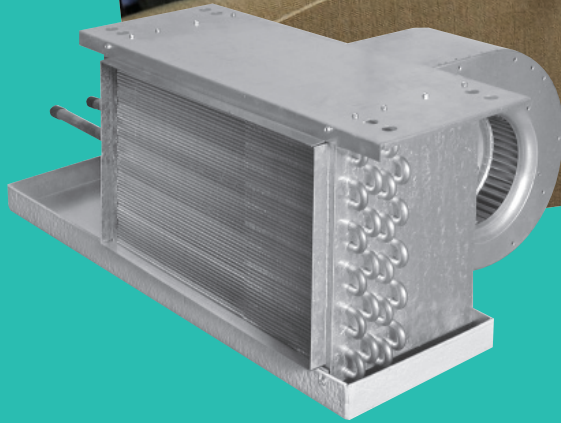

# TABLE OF CONTENTS

Features and Benefits .....	3
Unit Arrangements .....	4
Construction Features .....	6
Standard and Optional Features .....	8
Coils, Physical Data .....	9
Physical Data .....	10
Electric Heat .....	11
Fan Performance Curves, PSC.....	12
ECM™ Fan Motor Option.....	16
Performance Fan Curves, ECM™ Motors .....	17
Motor and Fan Data .....	19
Dimensional Data .....	20
Guide Specifications.....	27



**NOTES:**

- Johnson Controls offers Web-Select®, the industry’s first web-based rating and selection program for complete unit, coil and sound selection. See your representative or visit our website at [www.johnsoncontrols.com](http://www.johnsoncontrols.com) for more information.
- Some drawings are not shown in this catalog.
- All data herein is subject to change without notice.
- Drawings not for installation purposes.
- ETL Report Number 3036742-001.

## FEATURES AND BENEFITS

---

### HIGH PERFORMANCE

The Johnson Controls FN Series horizontal high performance fan coil units are designed to maximize flexibility of selection and installation.

The units are also designed to exceed the stringent quality standards of the institutional market, while remaining cost competitive in the light commercial segment of the market.

Johnson Controls horizontal fan coil units set the new standards for quality, flexibility, and competitive pricing.

### DESIGN FLEXIBILITY

The extensive variety of standard options available on the FN Series units are where you find the versatility to fit any HVAC system designer's needs.

Options include: mixing box with linkage, rear or bottom ducted return, foil faced or elastomeric closed cell foam insulation, solid or telescoping bottom panels for unit recessing, single wall stainless steel drain pans, and electric heat with single power connection. All electric heat units are listed with ETL as an assembly and carry the cETL label.

All units comply with the latest edition of AHRI Standard 440 for testing and rating fan coil units, are certified, and display the AHRI symbol. Sizes 14 through 20 exceed the maximum airflow rate in AHRI 440 and are outside of the scope of certification.

High efficiency motors, fan relays, disconnects and fusing mean easier coordination between mechanical and electrical trades.

Coil options allow for three, four or six row chilled water or DX coils. One to four row hot water or one and two row standard steam coils may be placed in the preheat or reheat position.

### CONVENIENT INSTALLATION

All FN Series fan coil units are shipped completely assembled, reducing field installation time and labor.

All units are thoroughly inspected and tested prior to shipment, eliminating potential problems at startup. Motor wiring is brought to a junction box on the outside of the unit casing, reducing electrical hook-up time.

Plenum units are field reversible for either rear or bottom return without the need for special adapters and tools.

All coils and drain pans are field reversible for right or left side connections.

All FN Series fan coil units have a side access electrical enclosure, allowing easy access to all electrical components, terminal blocks and wiring.

Available factory installed control packages can greatly reduce field labor and setup time. Consisting of control transformer and all needed relays, these packages integrate seamlessly with either factory provided thermostats or field installed thermostats and controllers.

Factory furnished valve packages assure proper fit, operation and performance. Valve packages are completely assembled and shipped loose with the units.

### QUALITY PRODUCT

FN Series fan coil units are built from galvanized steel. Exposed Model FNX cabinetry is powder coated galvanized steel.

Standard insulation is 1/2 inch thick fiberglass, complying with UL 181 and NFPA 90A. Optional foil faced or elastomeric closed cell foam insulation may be specified.

All units, with or without electric heat, are cETL listed and labeled. All wiring is in compliance with NEC, assuring safety and quality for the owner.

FN Series fan coil units have a removable fan assembly. The entire fan assembly can be removed from the unit and serviced easily on a workbench.

# UNIT ARRANGEMENTS

**FNP BOTTOM RETURN**

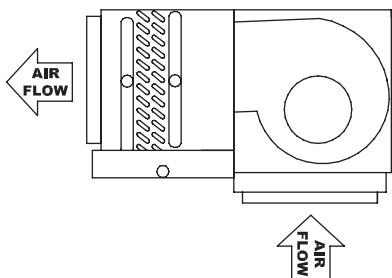

**FNP REAR RETURN WITH SOLID ACCESS PANEL**

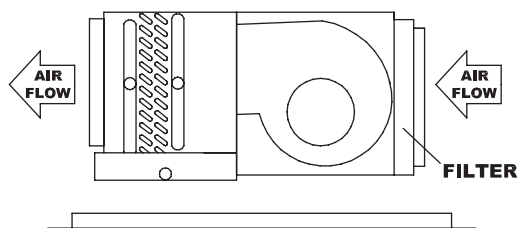

**FNP REAR RETURN**

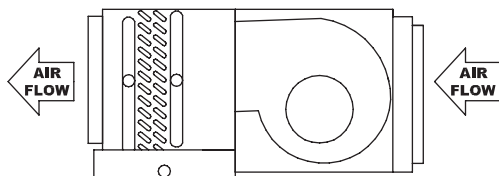

**FNP BOTTOM RETURN W/BOTTOM CEILING PANEL**

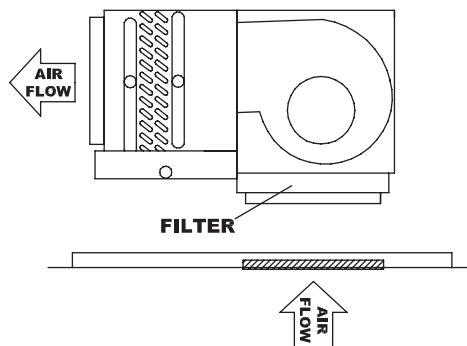

**FNP BOTTOM RETURN WITH TELESCOPING BOTTOM PANEL**

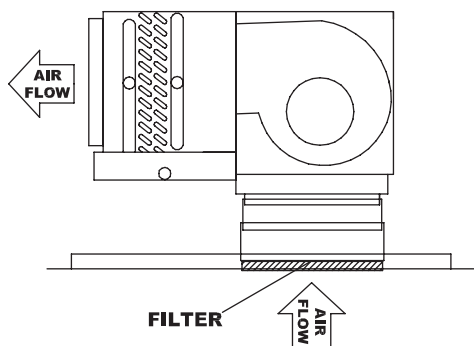

**FNF FREE RETURN**

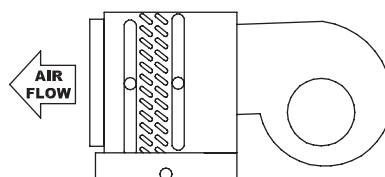

**FNP MIXING BOX WITH TOP & REAR RETURN**

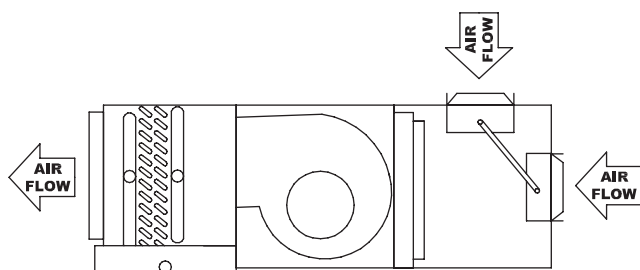

**FNP MIXING BOX W/BOTTOM & REAR RETURN**

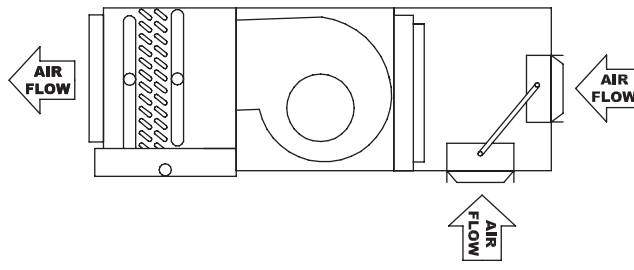

# UNIT ARRANGEMENTS

**FNX DOUBLE DEFLECTION SUPPLY GRILLE AND DUCTED REAR RETURN**

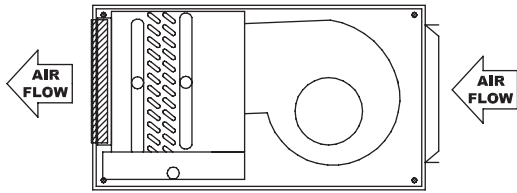

**FNX DUCTED SUPPLY AND SINGLE DEFLECTION REAR RETURN GRILLE**

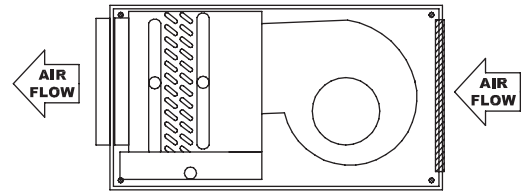

**FNX DOUBLE DEFLECTION SUPPLY GRILLE AND SINGLE DEFLECTION BOTTOM RETURN GRILLE**

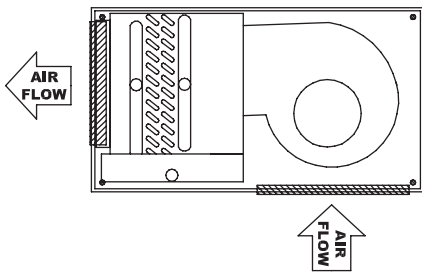

**FNX DUCTED SUPPLY AND DUCTED REAR RETURN**

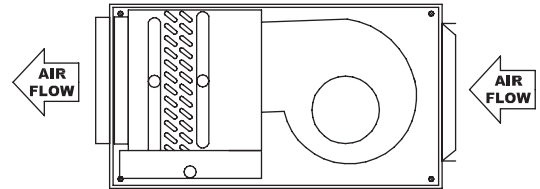

**FNX DOUBLE DEFLECTION SUPPLY GRILLE AND SINGLE DEFLECTION REAR RETURN GRILLE**

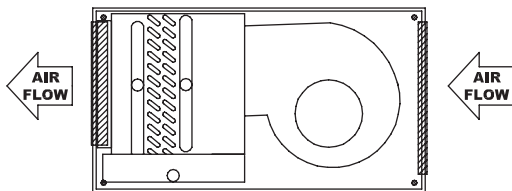

**FNX DUCTED SUPPLY AND SINGLE DEFLECTION BOTTOM RETURN GRILLE**

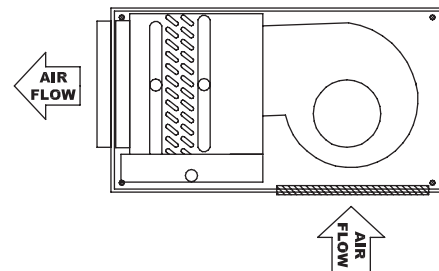



# CONSTRUCTION FEATURES

## MODEL FNP

FN Series fan coils have many standard and optional features which are unique to the industry (see page 8 for a complete listing).

1/2" thick fiberglass insulation (standard) or foil faced or elastomeric closed cell foam insulation (optional)

Galvanized steel casing

1" minimum duct collar allows quick field connection of duct work

Integral filter rack with 1" filter and integral rear ducted (shown) or bottom return on all plenum units. Optional 2" filter available.

ETL and AHRI 440 listed and labeled

Coils are AHRI 410 listed and labeled

Chilled water or DX cooling coils up to 6 rows

Hot water heating coils up to 4 rows, or steam coils up to 2 rows can be mounted in the preheat or reheat position. Maximum of 8 rows total.

Permanently lubricated, three tap, PSC fan motors designed for quiet and efficient operation

Optional electric resistance heat is ETL listed as an assembly for safety compliance

Single wall galvanized or stainless steel (optional) drain pans are double sloped to drain connections

Drain pans can be easily removed for cleaning, and reversed for opposite side drain connections

Single point power connection on all units with electric heat

Removable fan assembly for bottom or rear access and servicing

Enclosure allows easy side access to all electrical components

Optional auxiliary drain connection for added security (not shown)

## MODEL FNX

Horizontal Exposed Cabinet



## MODEL FNF

Horizontal Free Return

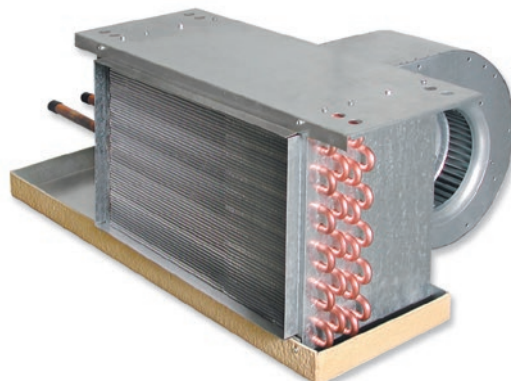

# CONSTRUCTION FEATURES

## MODELS FNF/FNP/FNX

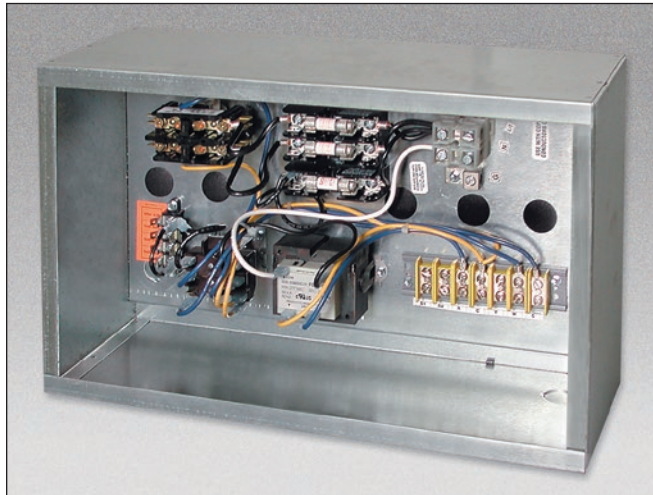

### ELECTRICAL ENCLOSURE

The side access electrical enclosure provides access to all electric heat and control components. Terminal strips are furnished for simple power and control wiring connections. Multiple knockouts allow wiring entries from either side of the compartment.

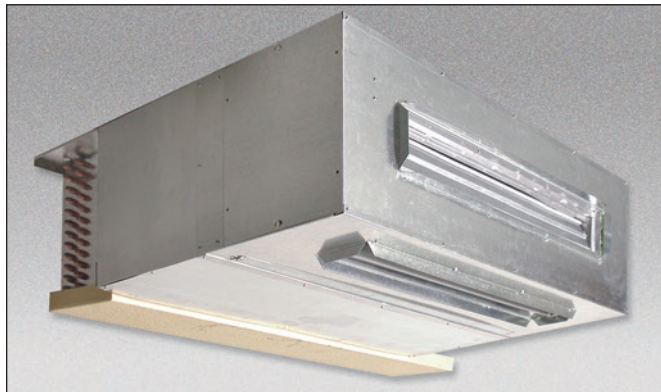

### MIXING BOX

The optional fully insulated mixing box section comes completely assembled to the FNP unit, featuring low leakage, heavy gauge steel dampers with integral linkage. Damper positioning is field configurable and bottom filter access is standard. An optional factory provided and installed damper actuator is also available.

### COILS

All fan coils are available in 2 or 4 pipe configurations. The heating coil may be placed in the reheat or preheat position. Heating and cooling coils are field reversible for right or left side connections.

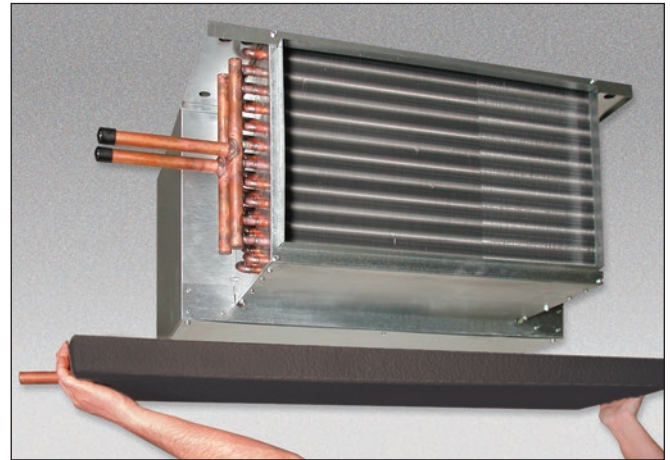

### DRAIN PAN

Standard drain pans are externally insulated, single wall galvanized steel with an option for stainless steel. Drain pans are available with secondary drain connection. On concealed models, the FN Series drain pan is easily removable for cleaning or reversing connections.



### FILTERS

One inch throwaway filters are tight fitting to prevent air bypass. Filters are easily removable from the bottom without the need for tools. The filter rack is convertible from rear to bottom return without the need for additional parts. Optional 1" and 2" pleated filters are available for use with the FNP unit.

### POWDER COATED PAINTED SURFACE

Exposed cabinet Model FNX features powder coat finish that resists scuffing, scratching, fading, and fingerprints.



## FEATURES AND OPTIONS

---

### STANDARD FEATURES

#### Construction

##### All Units

- AHRI 440 certified and labeled
- Galvanized steel construction
- 1/2" thick fiberglass insulation
- 1 1/2" duct discharge collar
- Holes are provided at four points for hanging units

##### Plenum units

- Integral filter rack with 1" throwaway filter
- Integral rear ducted return - field reversible to bottom return

##### Exposed units

- Single deflection rear return grille
- Double deflection discharge grille
- Durable powder coat paint
- 18 gauge cabinet construction

#### Coils

- AHRI 410 certified and labeled
- Cooling - 3, 4 or 6 row chilled water or DX, heat pump compatible
- Heating - 1, 2, 3 or 4 row hot water or 1 or 2 row steam - reheat or preheat position
- 8 total rows of cooling and heating coils maximum
- 3/8" O.D. seamless copper tubes
- 0.012" tube wall thickness
- High efficiency aluminum fin surface for optimizing heat transfer, pressure drop and carryover
- Left or right hand connections – field reversible (water coils only)
- Removable for service
- Manual air vent

#### Drain Pans

- Single wall, galvanized steel, externally insulated – fire retardant and antimicrobial closed cell foam
- Double sloped to drain connection
- Removable, field reversible
- 7/8" O.D. primary drain connection

#### Fan Assemblies

- Forward curved, DWDI centrifugal type
- 115 volt, single phase, three tap PSC motors
- Quick disconnect motor connections
- Removable fan(s)/motor(s) for service

#### Electrical

- cETL listed for safety compliance
- Electrical junction box for field wiring terminations
- Terminal block for field connections

#### Electric Heat

- cETL listed as an assembly for safety compliance
- Integral electric heat assembly with removable elements for easy service
- Automatic reset primary and back-up secondary thermal limits
- Single point power connection
- Side-hinged electrical enclosure

### OPTIONAL FEATURES

#### Construction

##### All units

- Foil faced fiberglass insulation
- Elastomeric closed cell foam insulation

##### Plenum units

- Bottom return
- Mixing box with top/rear or rear/bottom dampers - field reversible
- Damper actuator
- Spare 1" throwaway filters
- 1" and 2" pleated filters

##### Exposed units

- Single deflection bottom return grille
- Ducted supply
- Ducted rear return

#### Coils

- 1/2" O.D. seamless copper tubes
- 0.016" tube wall thickness
- 0.025" tube wall thickness
- Automatic air vents
- Stainless steel coil casings

#### Drain Pans

- Stainless steel with external insulation
- 5/8" O.D. secondary drain connection
- Auxiliary drip pans

#### Fan Assemblies

- 208-230 & 277 volt, single phase, three tap PSC motors
- ECM™ motors

#### Electrical

- Side access electrical enclosure
- Silent solid state fan relays
- SCR fan speed controller (only for high speed)
- Toggle disconnect switch
- Condensate overflow switch (drain pan)
- Main fusing
- Unit and remote mounted three speed fan switches
- Fan relay packages
- Control power transformers

#### Electric Heat

- Door interlocking disconnect switches
- Main fusing
- Silent relay / contactor

#### Piping Packages

- Factory assembled – shipped loose for field installation
- 1/2", 3/4", and 1", 2 way and 3 way normally closed, two position electric motorized valves
- Isolation ball valves with memory stop
- Fixed and adjustable flow control devices
- Unions and P/T ports
- Modulating control valves
- High pressure close-off actuators (1/2" = 50 PSIG; 3/4" = 25 PSIG; 1" = 20 PSIG)

#### Thermostats

- Remote mounted analog, digital display or programmable
- 2 and 4 pipe control sequences
- Automatic and manual changeover
- Integral three speed fan switches



# COILS, PHYSICAL DATA

## COILS

Johnson Controls offers hot water, chilled water, direct expansion (DX), and standard steam coils for specific application with all FN Series Fan Coil Units. Strict on-site inspection before, during, and after installation guarantees the highest quality and performance available.

### STANDARD FEATURES

- Cooling - 3, 4 or 6 row chilled water or DX
- Heating - 1, 2, 3 or 4 row hot water, or 1 or 2 row steam
- 8 total rows of cooling and heating coils maximum
- 3/8" O.D. seamless copper tubes
- 0.012" tube wall thickness
- High efficiency aluminum fin surface for optimizing heattransfer, pressure drop and carryover
- Left or right hand connections
- Manual air vents

### OPTIONAL FEATURES

- 1/2" O.D. seamless copper tubes
- 0.016" tube wall thickness
- 0.025" tube wall thickness
- Automatic air vents
- Stainless steel coil casings
- DX coils are heat pump compatible

**Web Select.** Johnson Controls offers the industry's first web-based fan coil rating and selection program for complete unit, coil and sound selection. See your representative for more information.

### NOMINAL COIL CONNECTION SIZES

UNIT SIZE	COIL TYPE						
	WATER					STEAM	
	1 ROW	2 ROW	3 ROW	4 ROW	6 ROW	1 ROW	2 ROW
06	5/8 [16]	5/8 [16]	7/8 [22]	7/8 [22]	7/8 [22]	5/8 [16]	7/8 [22]
08	5/8 [16]	5/8 [16]	7/8 [22]	7/8 [22]	7/8 [22]	5/8 [16]	7/8 [22]
10	5/8 [16]	5/8 [16]	7/8 [22]	7/8 [22]	7/8 [22]	5/8 [16]	7/8 [22]
12	5/8 [16]	7/8 [22]	7/8 [22]	7/8 [22]	1 1/8 [29]	7/8 [22]	7/8 [22]
14	5/8 [16]	7/8 [22]	7/8 [22]	1 1/8 [29]	1 1/8 [29]	7/8 [22]	1 1/8 [29]
16	5/8 [16]	7/8 [22]	7/8 [22]	1 1/8 [29]	1 1/8 [29]	7/8 [22]	1 1/8 [29]
18	5/8 [16]	7/8 [22]	1 1/8 [29]	1 1/8 [29]	1 1/8 [29]	7/8 [22]	1 1/8 [29]
20	5/8 [16]	7/8 [22]	1 1/8 [29]	1 1/8 [29]	1 1/8 [35]	7/8 [22]	1 1/8 [29]

**NOTES:**

1. All dimensional data is outside diameter (O.D.), measured in inches [millimeters].
2. See submittal drawings for connection locations.
3. Connection sizes are for standard circuit coils. Consult factory for special applications.
4. Direct Expansion (DX) suction header connection sizes are either 5/8" [16mm] or 7/8" [22mm]. Refer to coil selection.
5. DX coils include a fixed orifice distributor for multi-circuited coils. A DX coil with a single circuit requires no distributor. Thermal expansion valves (TXV's) are field supplied by others.

### FACE AREA, FREE AREA AND FILTER SIZES

UNIT SIZE	COIL FACE AREA	NOMINAL FILTER SIZES	1" THROWAWAY FACE AREA	1" PLEATED GROSS MEDIA AREA	2" PLEATED GROSS MEDIA AREA
06	1.46 [0.14]	(1) 16 x 16 [406 x 406]	1.62 [0.15]	4.0 [0.37]	5.4 [0.50]
08	1.94 [0.18]	(1) 16 x 20 [406 x 508]	2.04 [0.19]	4.8 [0.45]	6.8 [0.63]
10	2.33 [0.22]	(1) 16 x 25 [406 x 381]	2.57 [0.24]	6.0 [0.56]	8.5 [0.79]
12	2.82 [0.26]	(2) 16 x 16 [406 x 406]	3.23 [0.30]	8.0 [0.74]	10.4 [0.97]
14	3.31 [0.31]	(1) 16 x 16 & (1) 16 x 20 (1) [406 x 406] & (1) [406 x 508]	3.65 [0.34]	8.8 [0.82]	12.2 [1.13]
16	3.79 [0.35]	(2) 16 x 20 [406 x 508]	4.08 [0.38]	9.6 [0.89]	13.4 [1.24]
18	4.28 [0.40]	(1) 16 x 20 & (1) 16 x 25 (1) [406 x 508] & (1) [406 x 635]	4.61 [0.43]	10.8 [1.00]	14.3 [1.33]
20	4.67 [0.43]	(2) 16 x 25 [406 x 635]	5.14 [0.48]	12.0 [1.11]	17.0 [1.58]

**NOTES:**

1. Face and free areas are in square feet [square meters].
2. Filter sizes are in inches [millimeters].

# PHYSICAL DATA

## AHRI STANDARD RATINGS

Model / Size	AHRI 440 Certified	Coil		Airflow CFM (Dry flow)	Cooling Capacity		Water		Power Input (Watts)
		Rows	FPI		QT (BTUH)	QS (BTUH)	Flow Rate (GPM)	WPD (ft-wg)	
FNF 06	*	4	10	693	21,770	16,440	4.4	6.5	247
FNF 08	*	4	10	900	31,080	22,570	6.2	12.0	375
FNF 10	*	4	10	1,068	32,560	24,060	6.5	7.9	457
FNF 12	*	4	10	1,409	45,450	33,870	9.1	7.4	494
FNF 14		4	10	1,930	60,430	45,300	12	13.0	750
FNF 16		4	10	2,131	64,250	48,830	12.8	8.1	914
FNF 18		4	10	2,228	71,430	53,050	14.3	10.8	914
FNF 20		4	10	2,362	70,080	54,170	14.1	3.8	914
FNP 06	*	4	10	669	21,110	15,940	4.2	6.1	247
FNP 08	*	4	10	950	26,260	20,200	5.2	5.1	375
FNP 10	*	4	10	1,001	31,230	22,920	6.3	7.5	457
FNP 12	*	4	10	1,438	45,820	34,290	9.1	7.4	494
FNP 14		4	10	1,826	52,830	40,930	10.5	5.4	750
FNP 16		4	10	1,852	58,910	44,020	11.7	7.1	914
FNP 18		4	10	1,916	64,700	47,300	12.8	8.9	914
FNP 20		4	10	1,999	70,020	50,520	13.9	11.0	914
FNX 06	*	4	10	594	19,410	14,500	3.8	5.4	247
FNX 08	*	4	10	741	27,490	19,520	5.5	10.2	375
FNX 10	*	4	10	846	27,460	19,940	5.4	6.0	457
FNX 12	*	4	10	1,193	38,930	28,050	7.7	11.6	494
FNX 14		4	10	1,491	51,630	37,480	10.2	9.6	750
FNX 16		4	10	1,666	54,840	40,570	10.9	6.3	914
FNX 18		4	10	1,762	61,820	44,640	12.4	8.5	914
FNX 20		4	10	1,855	66,550	47,670	13.2	9.9	914

**NOTES:**

1. Based on 80°F DB and 67°F WB EAT, 45°F EWT, 10°F temperature rise, high fan speed. Motor type is PSC and motor voltage is 115/1/60. Airflow under dry coil conditions. All models tested at 0.05" external static pressure.
2. Airflow rate CFM on sizes 14 through 20 exceed maximum ratings in AHRI 440 and are outside of the scope of certification.

## HEATING CAPACITY

UNIT TYPE	UNIT SIZE	NOM. CFM	1 ROW			2 ROW			3 ROW			4 ROW		
			QS (MBH)	GPM	WPD	QS (MBH)	GPM	WPD	QS (MBH)	GPM	WPD	QS (MBH)	GPM	WPD
FNF FNP	06	600	17.5	0.9	1.6	30.2	1.5	1.4	41.7	2.1	1.0	48.3	2.5	0.9
	08	800	24.3	1.2	3.2	41.8	2.1	2.6	57.6	2.9	2.0	66.5	3.4	1.6
	10	1000	27.8	1.4	0.8	52.4	2.7	4.1	70.5	3.6	1.5	80.6	4.1	1.0
	12	1200	34.5	1.8	0.9	61.8	3.2	1.8	86.4	4.4	2.3	98.8	5.1	1.6
	14	1400	41.3	2.1	1.7	73.4	3.8	2.6	98.6	5.0	1.4	117.1	6.0	1.8
	16	1600	48.1	2.5	2.4	85.1	4.4	3.6	114.5	5.9	1.9	126.5	6.5	0.6
	18	1800	54.9	2.8	3.2	96.8	5.0	4.9	130.4	6.7	2.5	144.7	7.4	0.7
	20	2000	61.0	3.1	4.1	107.5	5.5	6.1	145.3	7.4	2.4	161.7	8.3	0.9

**NOTES:**

1. Based on 70°F DB EAT, 180°F EWT, 40°F temperature drop, high fan speed.
2. FNX performance data varies from FNF and FNP units. Please use Web-Select® at [www.johnsoncontrols.com](http://www.johnsoncontrols.com) for FNX data.

## COIL WEIGHT DATA

UNIT SIZE	6	8	10	12	14	16	18	20
1 ROW - DRY	4 [2]	5 [2]	6 [3]	6 [3]	8 [4]	9 [4]	9 [4]	10 [5]
1 ROW - WET	5 [2]	7 [3]	8 [4]	9 [4]	11 [5]	12 [5]	14 [6]	14 [6]
2 ROW - DRY	8 [4]	10 [4]	11 [5]	13 [6]	16 [7]	17 [8]	19 [9]	20 [9]
2 ROW - WET	11 [5]	14 [6]	16 [7]	18 [8]	21 [10]	24 [11]	27 [12]	29 [13]
3 ROW - DRY	12 [5]	14 [7]	17 [8]	19 [9]	24 [11]	26 [12]	28 [13]	30 [14]
3 ROW - WET	16 [7]	20 [9]	24 [11]	27 [12]	32 [15]	36 [16]	41 [19]	43 [20]
4 ROW - DRY	17 [8]	20 [9]	24 [11]	27 [12]	33 [15]	32 [15]	35 [16]	38 [17]
4 ROW - WET	20 [9]	27 [12]	33 [15]	37 [17]	42 [19]	48 [22]	55 [25]	58 [26]
5 ROW - DRY	20 [9]	23 [10]	27 [12]	30 [14]	33 [15]	40 [18]	43 [19]	45 [20]
5 ROW - WET	25 [11]	30 [13]	36 [16]	41 [18]	45 [20]	54 [25]	60 [27]	64 [29]
6 ROW - DRY	24 [11]	29 [13]	35 [16]	39 [18]	46 [21]	53 [24]	57 [26]	59 [27]
6 ROW - WET	32 [14]	40 [18]	49 [22]	55 [25]	63 [28]	73 [33]	83 [38]	86 [39]
7 ROW - DRY	29 [13]	32 [14]	39 [17]	43 [20]	47 [21]	57 [26]	61 [28]	65 [29]
7 ROW - WET	37 [17]	42 [19]	51 [23]	56 [25]	60 [27]	72 [33]	78 [35]	82 [37]
8 ROW - DRY	32 [15]	37 [17]	44 [20]	49 [22]	53 [24]	63 [29]	67 [31]	71 [32]
8 ROW - WET	42 [19]	48 [22]	57 [26]	63 [29]	68 [31]	82 [37]	88 [40]	93 [42]

**NOTE:** Unit weight data is in pounds [kilograms].

# ELECTRIC HEAT

## STANDARD FEATURES

- ETL listed as an assembly for safety compliance
- Single point power connection
- Mounted in preheat position
- Automatic reset primary and back-up secondary thermal limits
- Internal wiring rated at 105°C
- Integral electric heat assembly with removable element for easy service



## USEFUL FORMULAS

$$kW^* = \frac{CFM \times \Delta T \times 1.085^{**}}{3413}$$

$$1\emptyset \text{ AMPs} = \frac{kW \times 1000}{Volts}$$

\* 1kW = 3413 BTU/H

\*\* Capacity at sea level

## Altitude Considerations:

Reduce by 0.034 for each 1000 ft. of altitude above sea level.

Example: 5000 ft./1000 ft. = 5

5 x 0.034 = 0.17

1.085 - 0.17 = 0.915

## OPTIONAL FEATURES

- Solid state silent relay
- Door interlocking disconnect switch
- Main fusing (for equal to or less than 48 AMPs)

## ELECTRICAL CALCULATIONS INFORMATION

1. Refer to MCA/MOP Calculator at [www.johnsoncontrols.com](http://www.johnsoncontrols.com) for MCA and/or MOP calculations.
2. Non-Fused Door Interlock Disconnect Switch shall be sized according to MCA.
3. Fused Door Interlock Disconnect Switch and Main Fusing shall be sized according to MOP.

## ELECTRIC HEAT SELECTION CHART (AMPS)

UNIT SIZE	MBH	6.8	8.5	10.2	11.9	13.7	17.1	20.5	23.9	27.3	30.7	34.1	41.0	47.8
	KW	2.0	2.5	3.0	3.5	4.0	5.0	6.0	7.0	8.0	9.0	10.0	12.0	14.0
	VOLTS	AMPS												
06	115	17.4	21.7	26.1	30.4	34.8								
	208	9.6	12.0	14.4	16.8	19.2								
	230	8.7	10.9	13.0	15.2	17.4								
	277	7.2	9.0	10.8	12.6	14.4								
08	115	17.4	21.7	26.1	30.4	34.8	43.5							
	208	9.6	12.0	14.4	16.8	19.2	24.0	28.8						
	230	8.7	10.9	13.0	15.2	17.4	21.7	26.1						
	277	7.2	9.0	10.8	12.6	14.4	18.1	21.7						
10	115	17.4	21.7	26.1	30.4	34.8	43.5							
	208	9.6	12.0	14.4	16.8	19.2	24.0	28.8	33.7					
	230	8.7	10.9	13.0	15.2	17.4	21.7	26.1	30.4					
	277	7.2	9.0	10.8	12.6	14.4	18.1	21.7	25.3					
12	115					34.8	43.5							
	208					19.2	24.0	28.8	33.7	38.5	43.3			
	230					17.4	21.7	26.1	30.4	34.8	39.1	43.5		
	277					14.4	18.1	21.7	25.3	28.9	32.5	36.1	43.3	
14	115					34.8	43.5							
	208					19.2	24.0	28.8	33.7	38.5	43.3	48.1		
	230					17.4	21.7	26.1	30.4	34.8	39.1	43.5	48.1	
	277					14.4	18.1	21.7	25.3	28.9	32.5	36.1	43.3	
16	115					34.8	43.5							
	208					19.2	24.0	28.8	33.7	38.5	43.3	48.1	57.7	
	230					17.4	21.7	26.1	30.4	34.8	39.1	43.5	52.2	
	277					14.4	18.1	21.7	25.3	28.9	32.5	36.1	43.3	
18	115					34.8	43.5							
	208					19.2	24.0	28.8	33.7	38.5	43.3	48.1	57.7	
	230					17.4	21.7	26.1	30.4	34.8	39.1	43.5	52.2	
	277					14.4	18.1	21.7	25.3	28.9	32.5	36.1	43.3	
20	115					34.8	43.5							
	208					19.2	24.0	28.8	33.7	38.5	43.3	48.1	57.7	67.3
	230					17.4	21.7	26.1	30.4	34.8	39.1	43.5	52.2	60.9
	277					14.4	18.1	21.7	25.3	28.9	32.5	36.1	43.3	50.5

### NOTES:

1. Shaded areas indicate kW and voltage options not available.
2. Available voltages are single phase, 60 hertz.
3. Heaters over 48 AMPs are subdivided and fused per NEC.

# FAN PERFORMANCE CURVES, PSC

## GENERAL FAN NOTES, PSC MOTORS

1. Fan curves depict actual performance of each motor tap without any additional fan balance adjustment. Actual capacities which fall below each curve can be obtained by adding an adjustment device. Units should not be run prior to installation of downstream ductwork; otherwise, damage to the motor may result.
2. Johnson Controls Fan Coil Units are equipped with permanent split-capacitor (PSC) motors with three separate taps (High, Medium and Low) which provide variable horsepower outputs. Most often, size selections are conservative and actual CFM requirements and/or external static pressure requirements are lower than those specified. In this case, the unit fan motor can be run at low or medium tap, substantially reducing the operating cost of the unit.
3. All fan curves are for 115/1/60 motors and include pressure losses for cabinet, electric heater, and 3 or 4 row coil. Plenum units include a clean 1" throwaway filter. For other coil configurations, adjust performance curves based on pressure losses for the coils as selected with the Johnson Controls Coil Selection Program.
4. See page 19 for fan motor electrical data.
5. For additional high static pressure applications and rating points, contact factory.

### SIZE 06

### SIZE 08

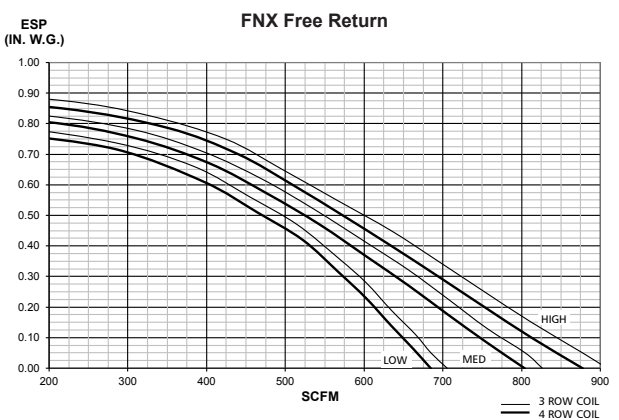
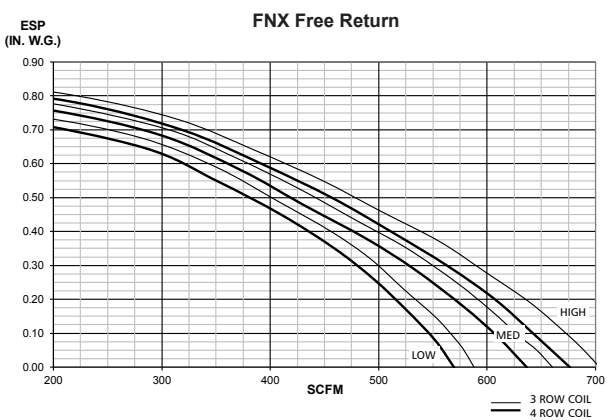
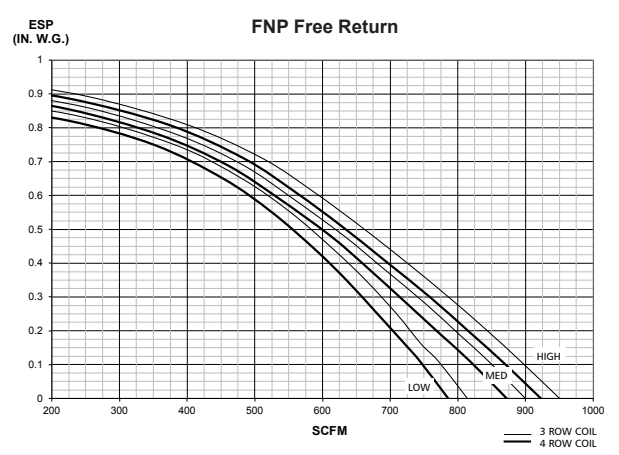
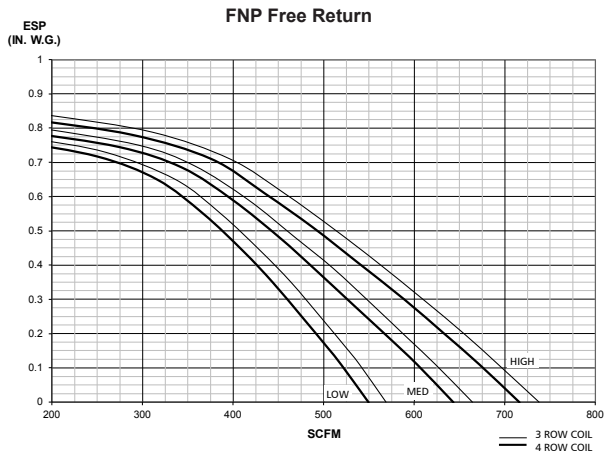
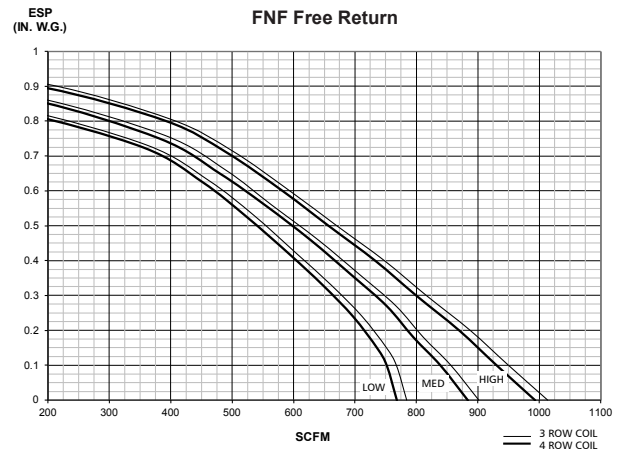
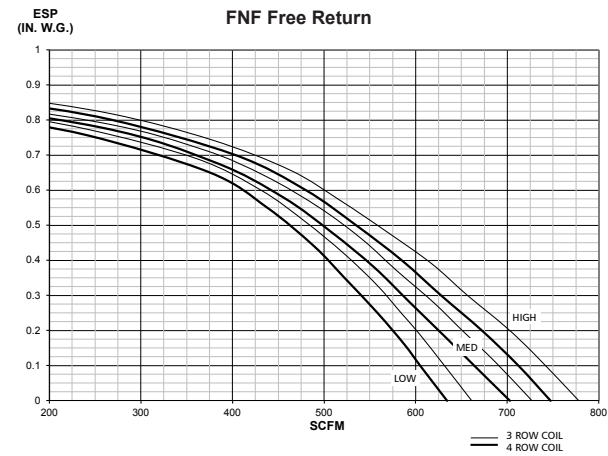



# FAN PERFORMANCE CURVES, PSC

## SIZE 10

## SIZE 12

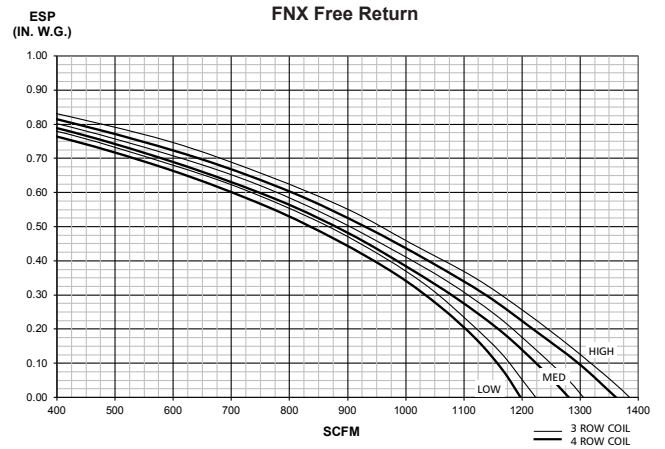
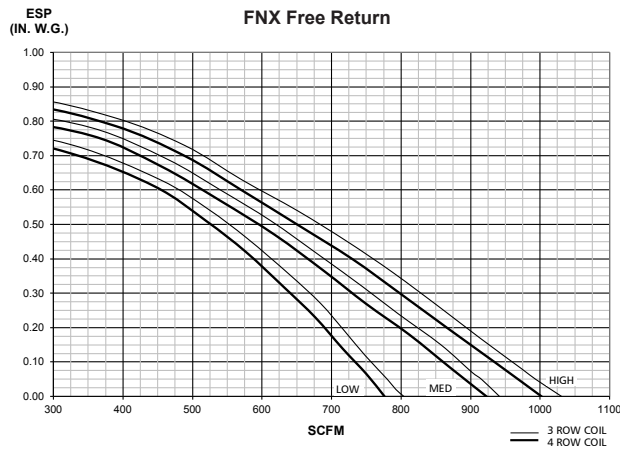
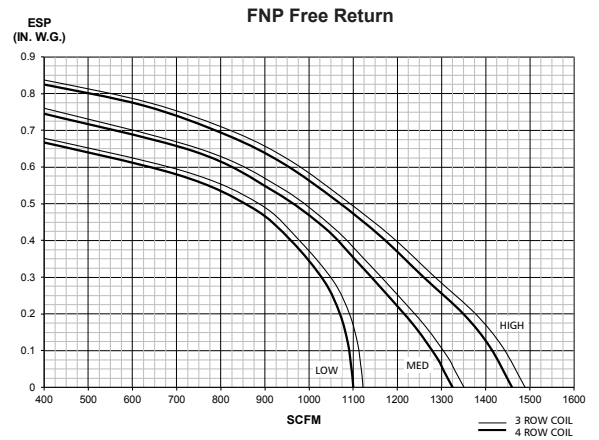
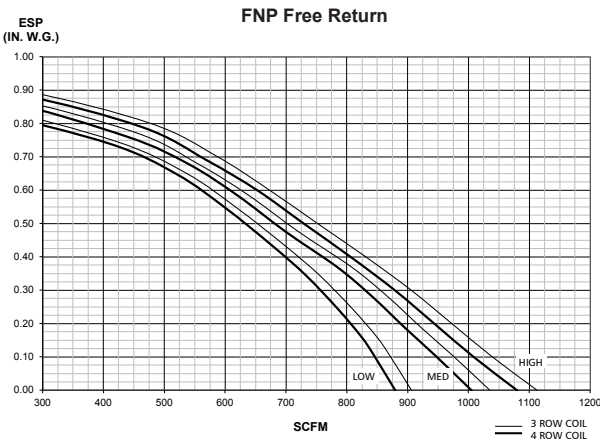
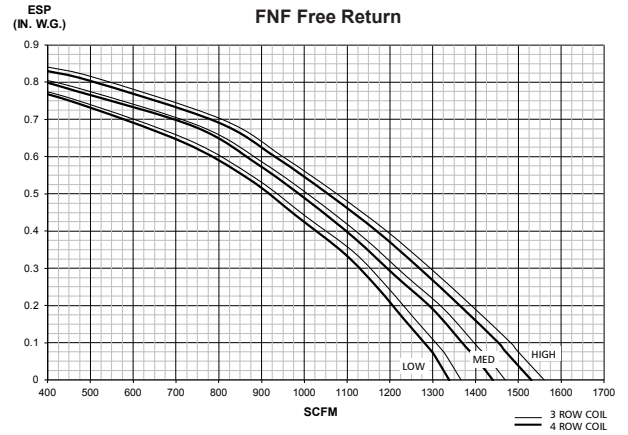
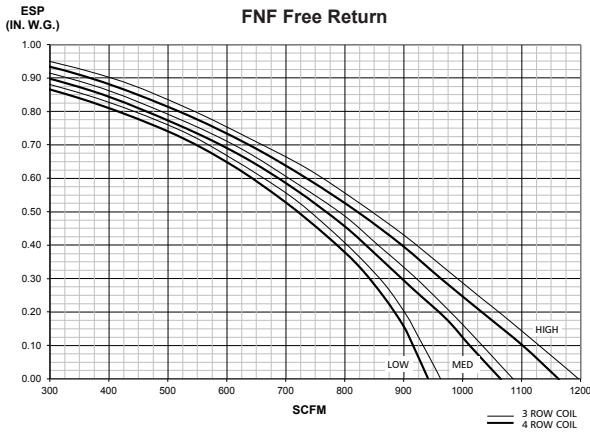

# FAN PERFORMANCE CURVES, PSC

## SIZE 14

## SIZE 16

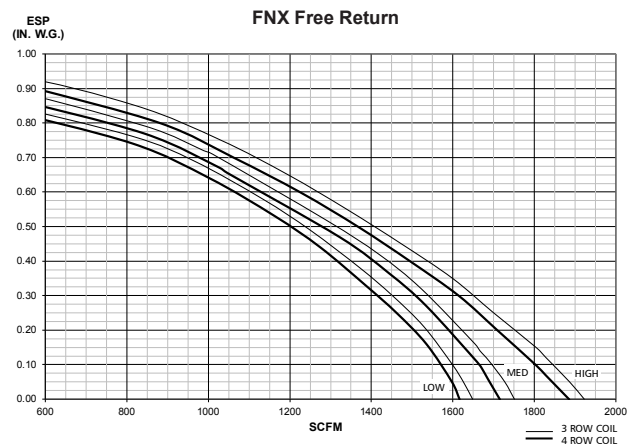
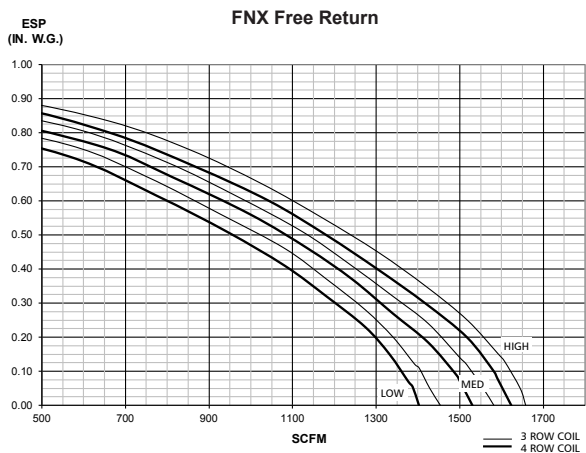
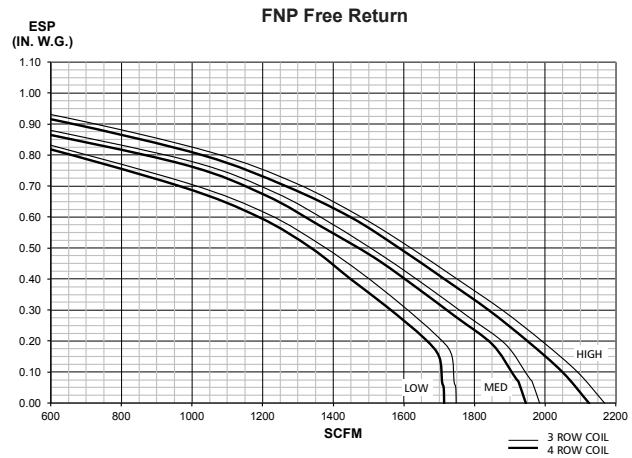
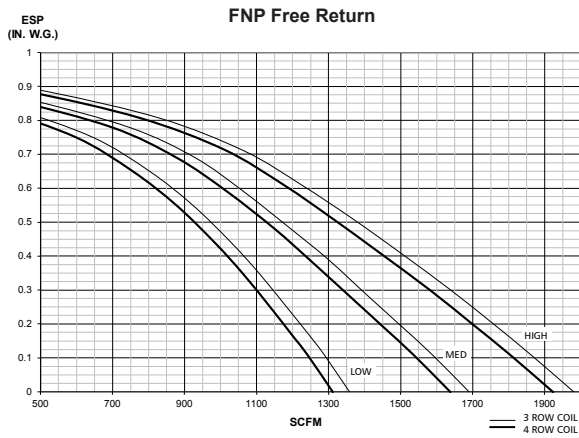
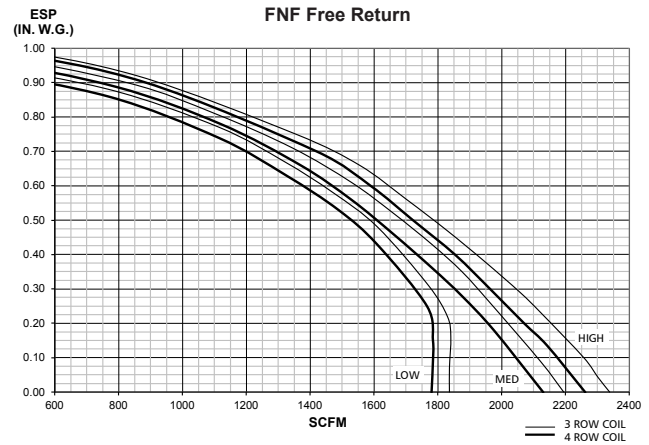
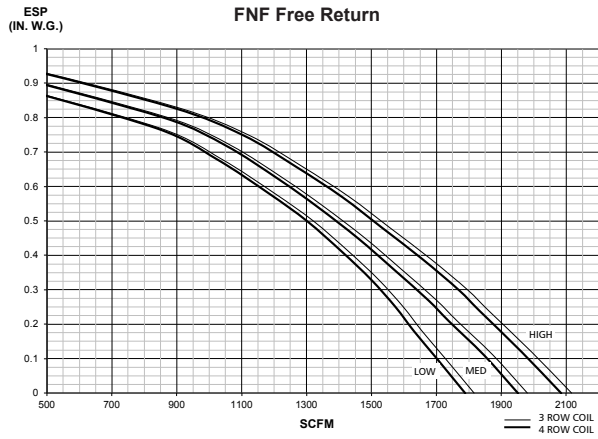

# FAN PERFORMANCE CURVES, PSC

## SIZE 18

## SIZE 20

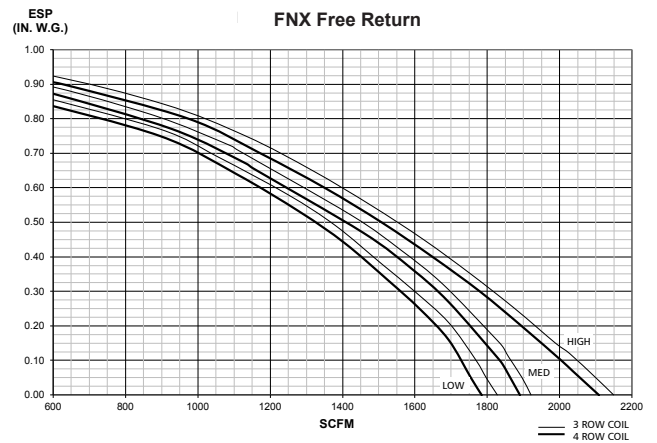
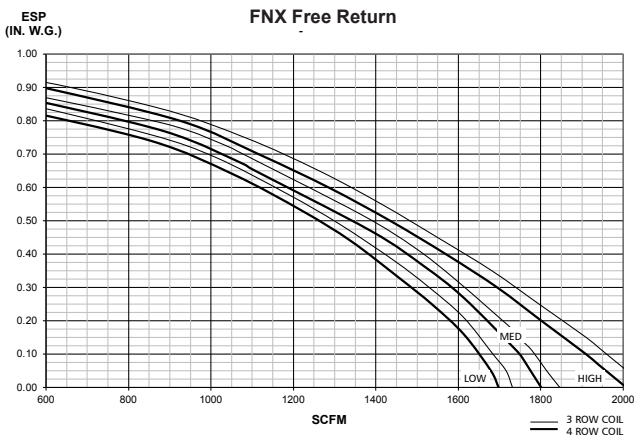
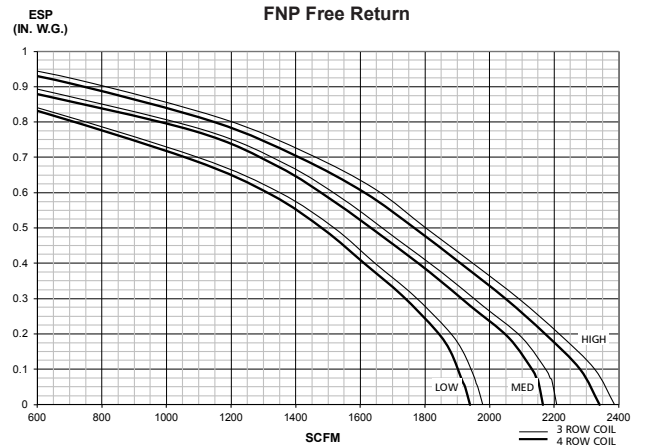
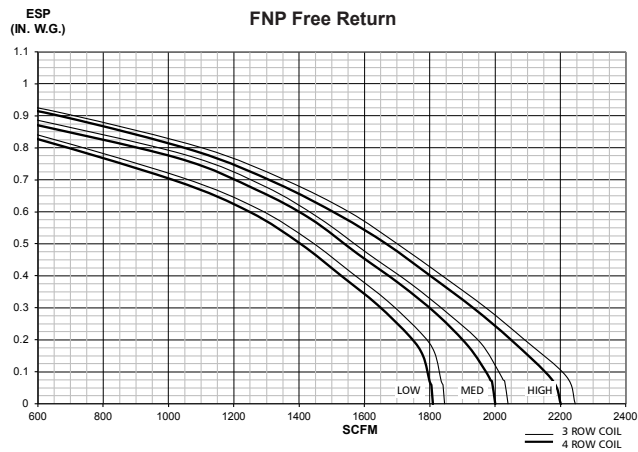
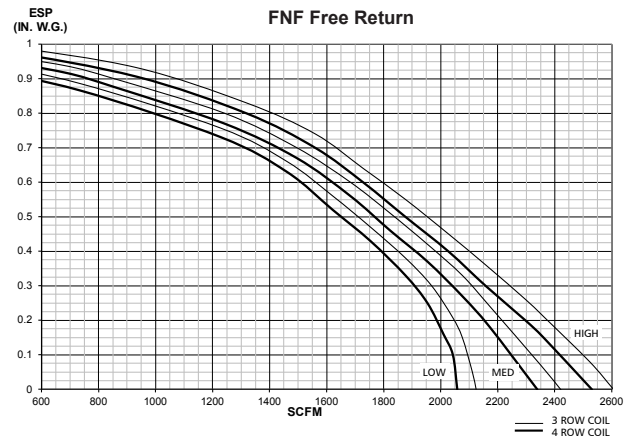
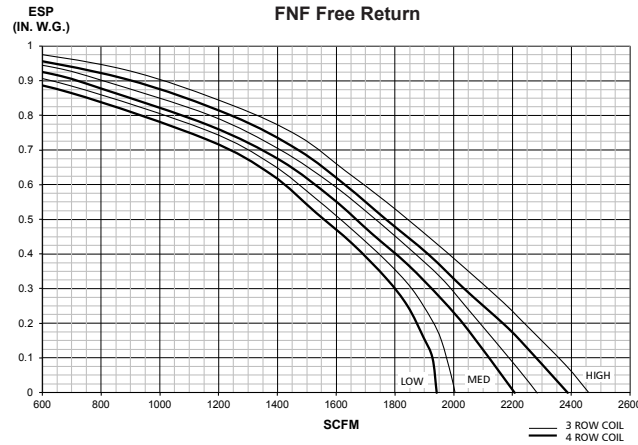

## EC MOTOR OPTIONS

### THE ENERGY EFFICIENT SOLUTION

Johnson Controls offers two high efficiency alternatives to the PSC motor. These are brushless DC (BLDC) motors with permanent magnet rotors, commonly referred to as ECMs (electronically commutated motors.) EC motors have been used for many years in residential HVAC units, and have now become the norm for high efficiency light commercial HVAC applications as well.

Johnson Controls offers two different types of EC motor in FN Series fan coil units. While each of these EC motors significantly increases the operating efficiency of Johnson Controls fan coils, they also provide different control and performance capabilities. For each motor, fan speed control is accomplished through a microprocessor based controller that electronically controls the speed of the motor. These motors provide peak efficiency ratings between 70 & 80% for most applications.

The first, full featured, EC motor offers two choices of motor control:

- 1) Three speed (user adjustable) operation. Each of the three speeds provides constant airflow, and can be independently adjusted in the field.
- 2) Continuously variable speed operation, constant airflow. This is achieved via proportional control from a remote 2 – 10V DC signal.

The second EC motor offering provides Constant Torque operation. This motor is factory programmed for three separate fixed torque settings, corresponding to three speed, high efficiency operation. The three speeds are not user adjustable. However, each of these motors is supplied with a high capacity or standard capacity plug which can be manually changed in the field to assist in balancing the system.

### ECM FEATURES AND BENEFITS

#### Ultra-High Motor & Controller Energy Efficiency

EC motors offer several advantages over PSC motors in fan Coils, including variable speed, constant CFM or constant Torque operation, and significantly higher efficiency. Due to the Permanent magnet rotor and electronic commutation, the EC Motor maintains approximately 75% efficiency at all speeds.

#### Designer / Owner Flexibility

The ECM incorporates ball bearings in lieu of sleeve bearings typically utilized with an induction motor.

Unlike a sleeve bearing motor, the ECM does not have a minimum RPM requirement for bearing lubrication. This allows it to operate over a much wider speed range, and provides for maintenance – free operation. A reduced spare parts inventory is another plus.

### Custom Applications —

#### Programmable Fan Operation

Boundless control opportunities arise for the EC motor due to the controllability of the permanent magnet rotor combined with programmable electronic commutation. Various input signals can direct the motor to behave in an application specific mode. For instance, multiple discrete fan capacities can be achieved. In addition, the fan speed can be varied in response to the space temperature load. By default, the fan is also programmed for a soft start. This means that the motor starts at a low speed and slowly ramps up to the required speed.



#### Extended Motor Life

The high motor efficiency provides a significantly reduced operating temperature compared to an induction motor. The lower temperature increases the longevity of all electrical components and therefore the life of the motor. The ball bearings do not require lubrication and do not adversely impact the motor life. Expected ECM motor life will be considerably longer than a PSC motor, due to the reduced operating temperature and ball bearing components.

#### Application

Most variable speed electronic devices, including the ECM operate with a rectified and filtered AC power. As a result of the power conditioning, the input current draw is not sinusoidal; rather, the current is drawn in pulses at the peaks of the AC voltage. This pulsating current includes high frequency components called harmonics. Harmonic currents circulate on the delta side of a Delta-Wye distribution transformer. On the Wye side of the transformer, these harmonic currents are additive on the neutral conductor. A transformer used in this type of application must be sized to carry the output KVA that will include the KVA due to circulating currents. Careful design must be provided when connecting single-phase products to three-phase systems to avoid potential problems such as overheating of neutral wiring conductors, connectors, and transformers. In addition, design consideration must be provided to address the degradation of power quality by the creation of wave shape distortion. In summary, proper consideration must be given to the power distribution transformer selection and ground neutral conductor design to accommodate the 3-phase neutral AMPs shown in the adjacent table. Specific guidelines are available from the factory.



# PERFORMANCE FAN CURVES, ECM™ MOTORS

## GENERAL FAN NOTES, ECM MOTORS

1. Fan curves depict actual performance at the maximum speed of the ECM motor. Depending upon external static pressure, flow rates are achievable anywhere within the curve boundary by adjusting the motor speed through the electronic interface control board.
2. Airflow rates will be constant for varying degrees of external static pressure caused by filter loading or other duct system variables once the electronic interface control board is set to desired flow rate.
3. Fan curves compensate for the pressure losses of the unit cabinet, coil rows, filter loading and other optional appurtances.
4. ECM motors operate using a rectified AC power source that is converted to a non-sinusoidal DC power wave form. Harmonic distortion may occur and circulate on the power distribution system. Circulating harmonic currents are potentially additive on the neutral conductors of 3-phase, 4-wire Wye distribution systems. Neutral conductors must be engineered to account for the additional current (amperes) encountered.
5. See page 19 for ECM motor electrical data.

FNP Size 06 with 1/3 HP ECM Motor

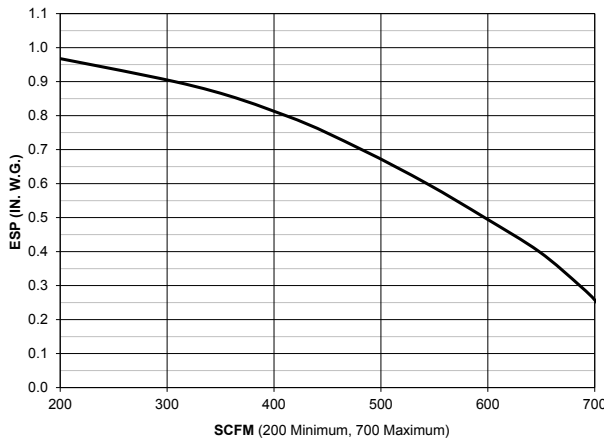

FNP Size 08 with 1/3 HP ECM Motor

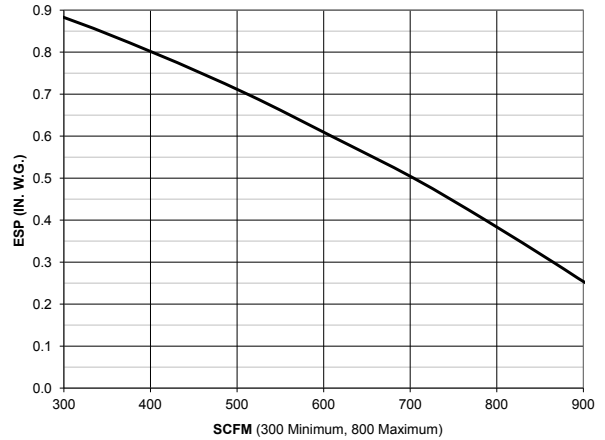

FNP Size 10 with 1/3 HP ECM Motor

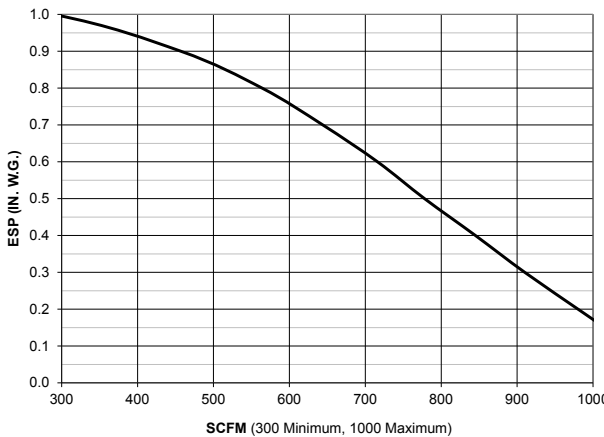

FNP Size 12 with (2) 1/3 HP ECM Motors

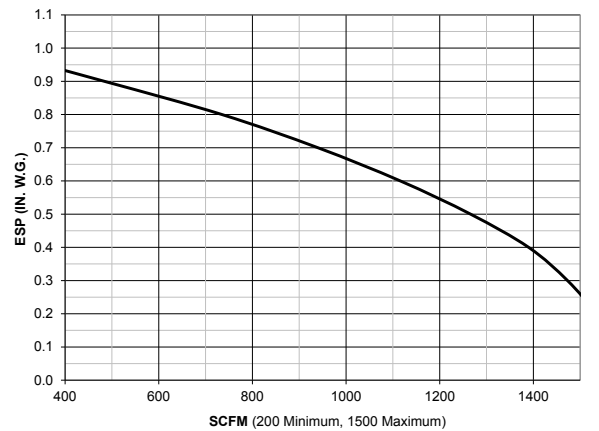

# PERFORMANCE FAN CURVES, ECM™ MOTORS

FNP Size 14 with (2) 1/3 HP ECM Motors

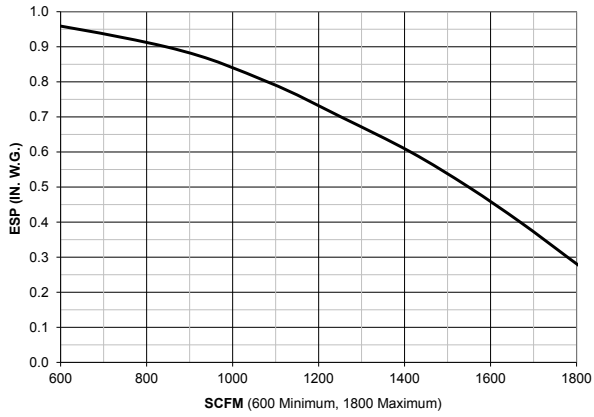

FNP Size 16 with (2) 1/3 HP ECM Motors

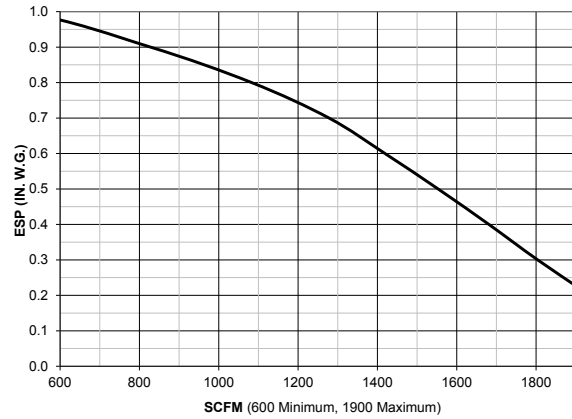

FNP Size 18 & 20 with (2) 1/3 HP ECM Motors

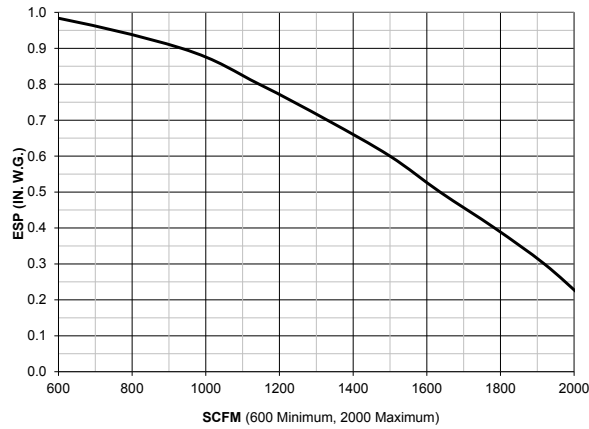

# MOTOR AND FAN DATA

## MOTOR AND FAN DATA

UNIT SIZE	FAN SPEED	MOTOR HP (Quantity)		# OF FANS	AMPS @ 120/1/60			AMPS @ 208-230/1/60			AMPS @ 277/1/60		
		PSC	ECM		PSC	ECM		PSC	ECM		PSC	ECM	
						FLA	3-Phase Neutral Current		FLA	3-Phase Neutral Current		FLA	3-Phase Neutral Current
06	High	(1) 1/6	(1) 1/3	1	2.6	5.0	8.7	1.0	2.8	4.8	0.9	2.6	4.5
	Medium	(1) 1/8			2.1			0.9			0.8		
	Low	(1) 1/10			1.8			0.6			0.7		
08	High	(1) 1/4	(1) 1/3	1	3.8	5.0	8.7	1.6	2.8	4.8	1.3	2.6	4.5
	Medium	(1) 1/6			3.3			1.0			0.8		
	Low	(1) 1/8			2.6			0.8			0.7		
10	High	(1) 1/4	(1) 1/3	1	4.9	5.0	8.7	2.0	2.8	4.8	1.9	2.6	4.5
	Medium	(1) 1/5			4.1			1.4			1.6		
	Low	(1) 1/6			3.2			1.2			1.3		
12	High	(2) 1/6	(2) 1/3	2	5.2	10.0	17.3	2.0	5.6	9.7	1.8	5.2	9.0
	Medium	(2) 1/8			4.2			1.8			1.6		
	Low	(2) 1/10			3.6			1.2			1.4		
14	High	(2) 1/4	(2) 1/3	2	7.6	10.0	17.3	3.2	5.6	9.7	2.6	5.2	9.0
	Medium	(2) 1/6			6.6			2.0			1.6		
	Low	(2) 1/8			5.2			1.6			1.4		
16	High	(2) 1/4	(2) 1/3	2	9.8	10.0	17.3	4.0	5.6	9.7	3.8	5.2	9.0
	Medium	(2) 1/5			8.2			2.8			3.2		
	Low	(2) 1/6			6.4			2.4			2.6		
18	High	(2) 1/4	(2) 1/3	2	9.8	10.0	17.3	4.0	5.6	9.7	3.8	5.2	9.0
	Medium	(2) 1/5			8.2			2.8			3.2		
	Low	(2) 1/6			6.4			2.4			2.6		
20	High	(2) 1/4	(2) 1/3	2	9.8	10.0	17.3	4.0	5.6	9.7	3.8	5.2	9.0
	Medium	(2) 1/5			8.2			2.8			3.2		
	Low	(2) 1/6			6.4			2.4			2.6		

**NOTES:**

1. Motor electrical data is nameplate data. Actual data will vary with application.
2. Motors nameplated for 208-230/1/60. Data is at 230 volts.
3. ECM motors operated on 208/1/60 power result in reduced airflow.

# DIMENSIONAL DATA

## FNF FREE RETURN UNITS

Drawings are not to scale and are not for installation purposes.

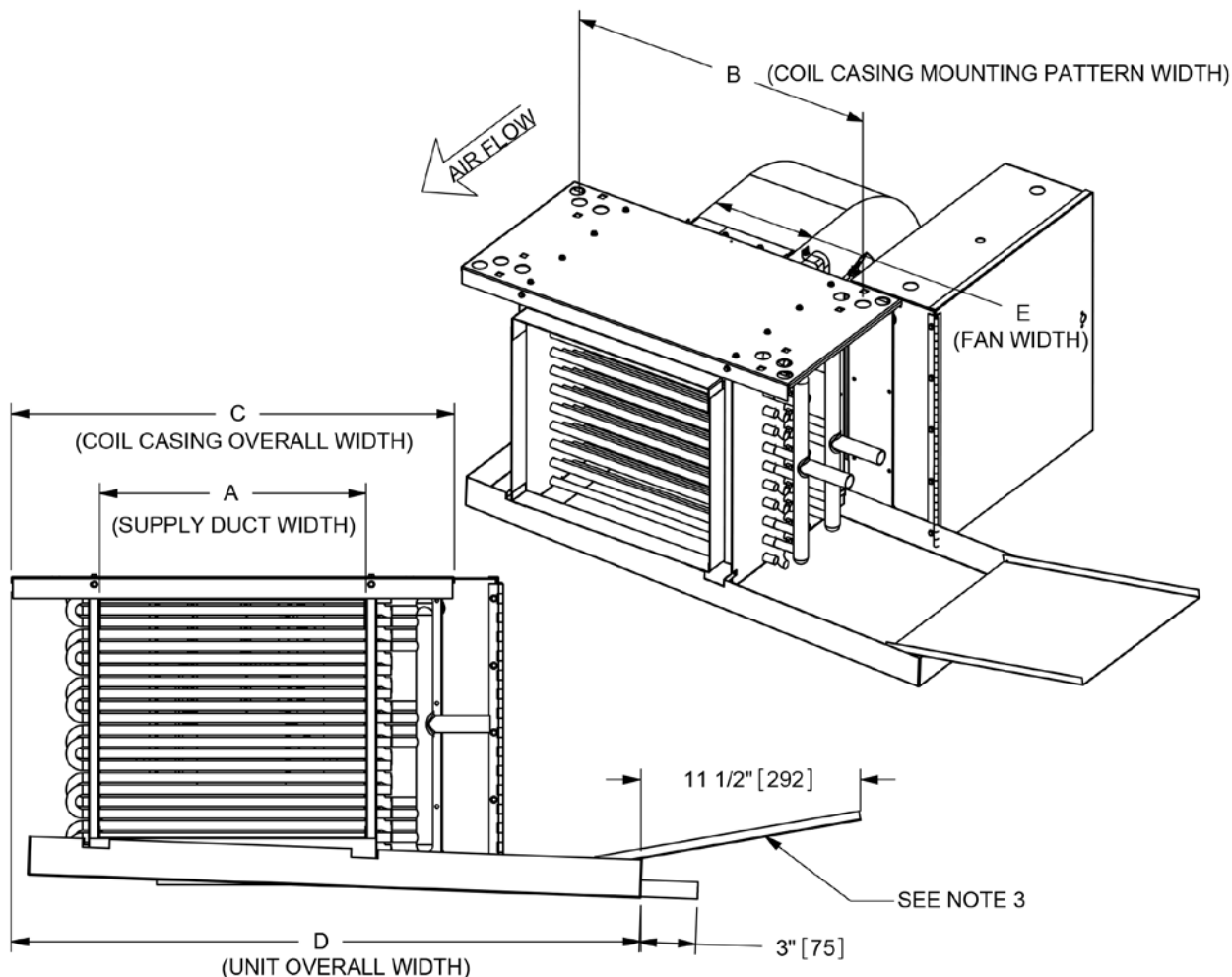

UNIT SIZE	FAN QTY	A	B	C	D	E
06	1	14 [356]	20 [508]	23 1/8 [587]	34 [864]	6 7/8 [175]
08	1	19 [483]	25 [635]	28 1/8 [714]	39 [991]	8 1/4 [210]
10	1	23 [584]	29 [737]	32 1/8 [816]	43 [1092]	8 1/4 [210]
12	2	28 [711]	34 [864]	37 1/8 [943]	48 [1219]	6 7/8 [175]
14	2	33 [838]	39 [991]	42 1/8 [1070]	53 [1346]	8 1/4 [210]
16	2	38 [965]	44 [1118]	47 1/8 [1197]	58 [1473]	8 1/4 [210]
18	2	43 [1092]	49 [1245]	52 1/8 [1324]	63 [1600]	8 1/4 [210]
20	2	47 [1194]	53 [1346]	56 1/8 [1426]	67 [1702]	8 1/4 [210]

**NOTES:**

1. ALL DIMENSIONS ARE IN INCHES [mm] AND ARE +/- 1/8"
2. DRAIN PAN IS FIELD REVERSIBLE 180° AND EXTERNALLY INSULATED
3. OPTIONAL AUXILIARY DRIP PAN AVAILABLE FOR PIPING PACKAGE CONDENSATE
4. COIL HAND IS FIELD REVERSIBLE (LEFT HAND UNIT SHOWN)



# DIMENSIONAL DATA

## FNF FREE RETURN UNITS

Drawings are not to scale and are not for installation purposes.

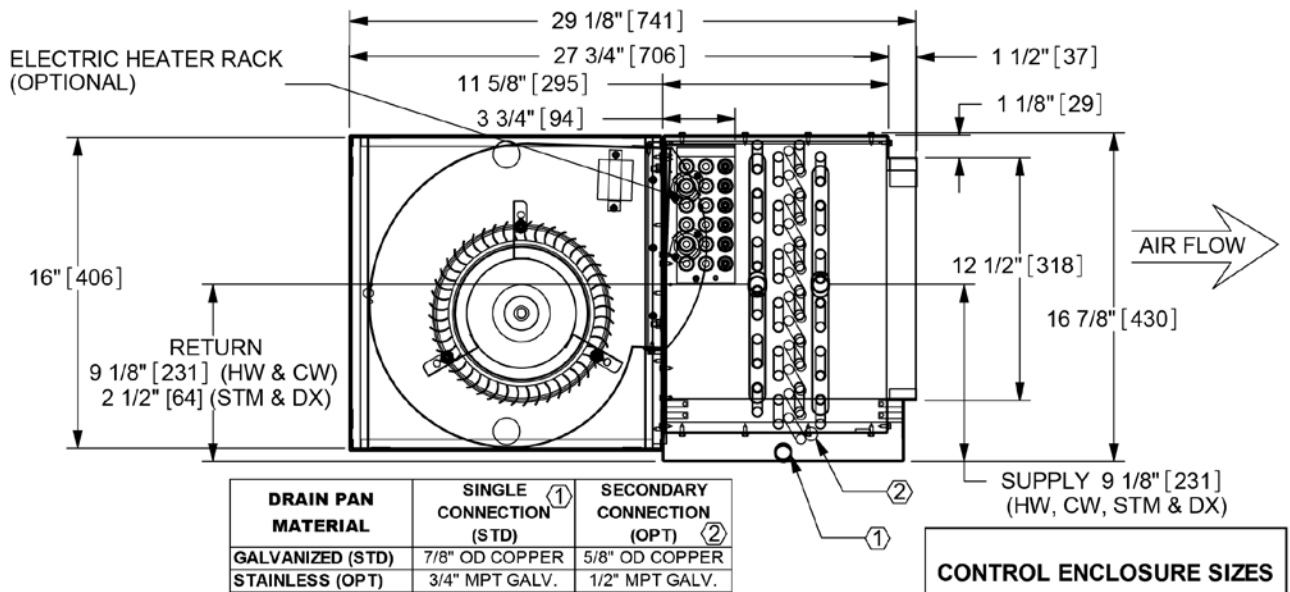
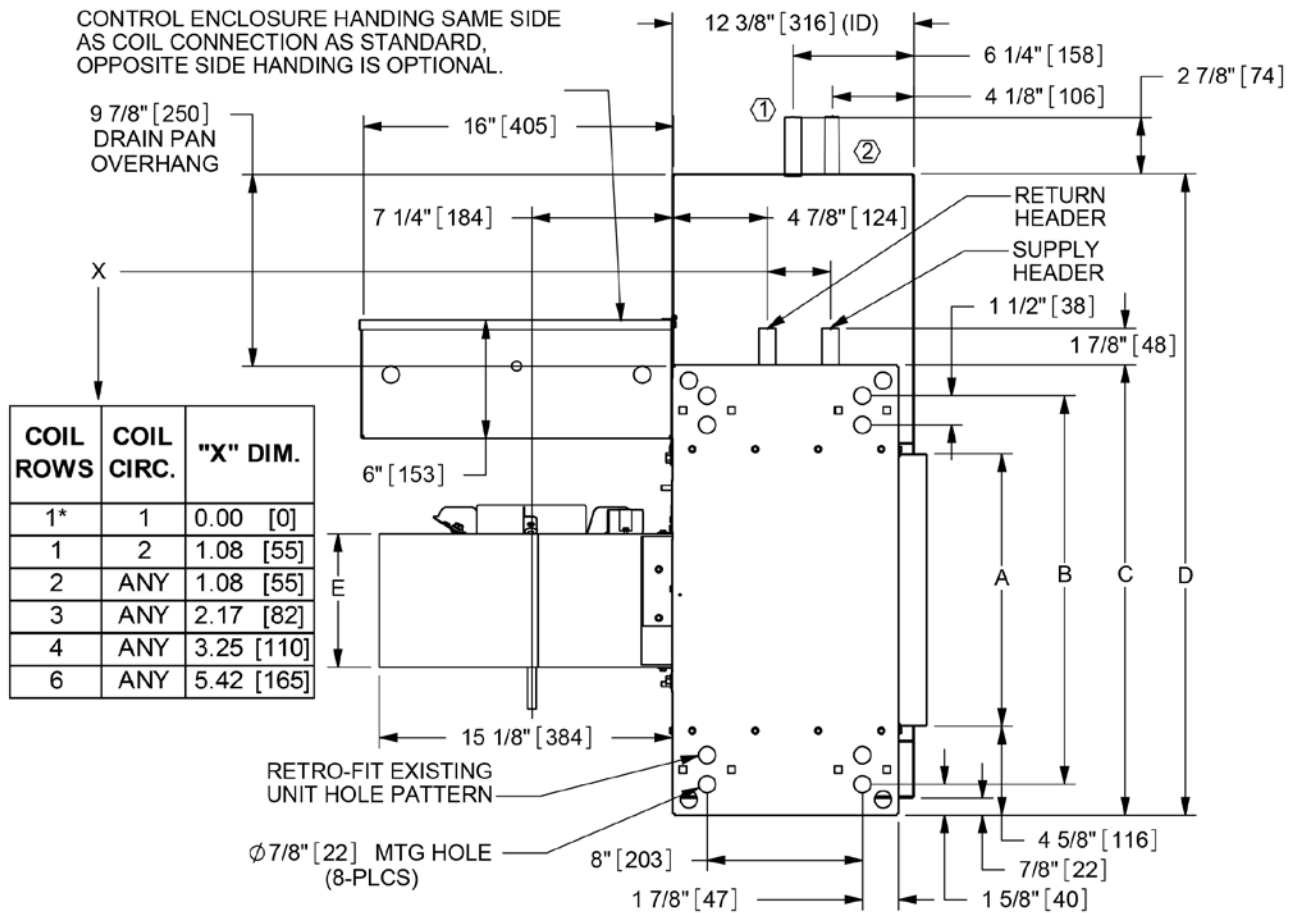

**NOTES:**

1. ALL DIMENSIONS ARE IN INCHES [mm] AND ARE +/- 1/8"
2. SEE SHEET 2 FOR SPECIFIC UNIT DIMENSIONS, OPTIONS AND SPECIFICATIONS
3. \* 1 ROW SINGLE CIRCUIT COILS ARE ON THE SAME AXIS, BUT ARE 13 3/4" APART IN HEIGHT
4. PROVIDE ACCESS CLEARANCE FOR ELECTRICAL ENCLOSURE PER LOCAL AND NATIONAL ELECTRICAL CODE REQUIREMENTS.
5. IT IS RECOMMENDED TO PROVIDE 3' ACCESS ON PIPE CONNECTION SIDE.

**CONTROL ENCLOSURE SIZES**

"SIZE DETERMINED BY SELECTED COMPONENTS"

10 X 16 X 6	[250 X 406 X 152]
16 X 16 X 6	[406 X 406 X 152]

# DIMENSIONAL DATA

## FNP PLENUM UNITS

Drawings are not to scale and are not for installation purposes.

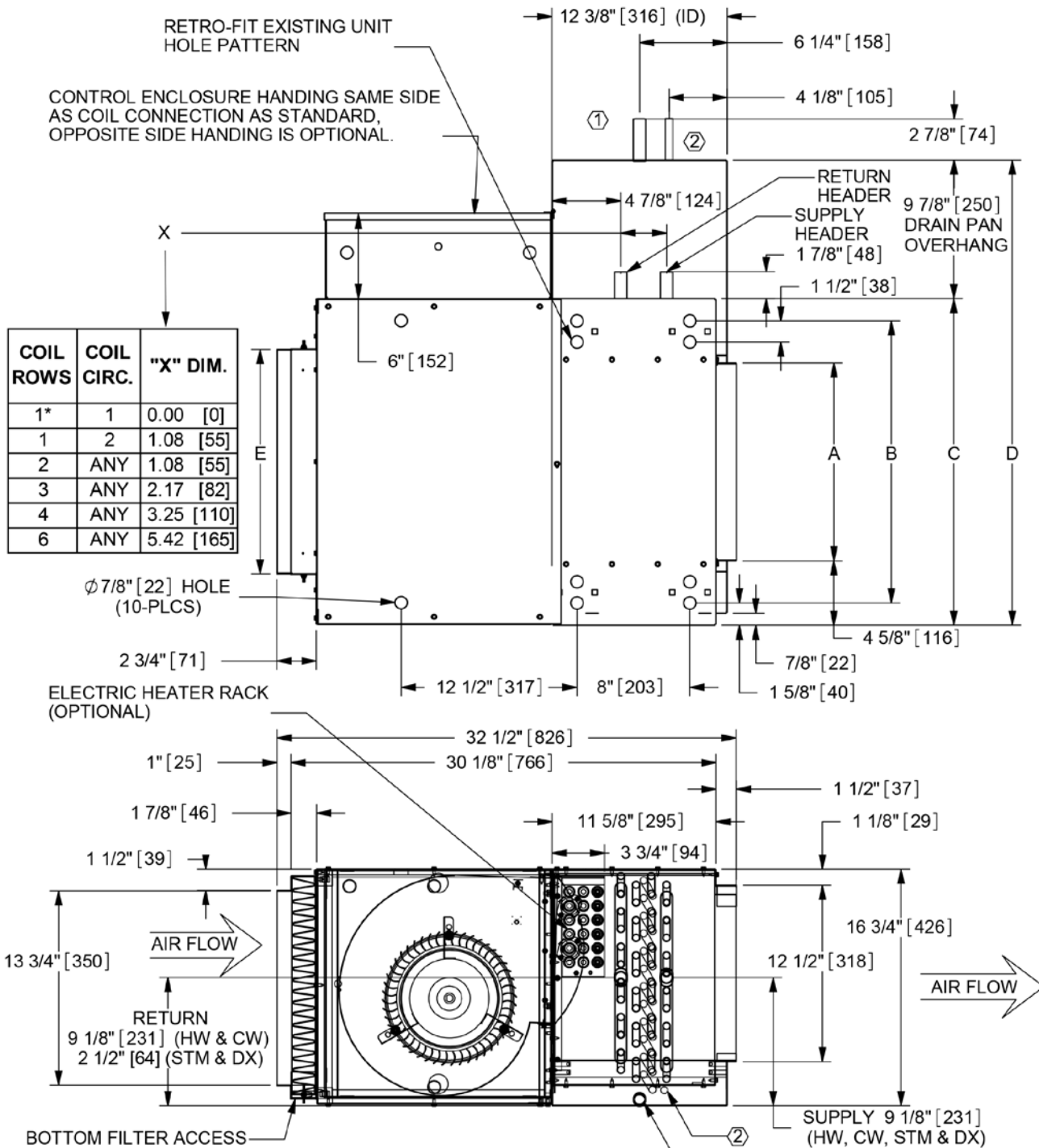

COIL ROWS	COIL CIRC.	"X" DIM.
1*	1	0.00 [0]
1	2	1.08 [55]
2	ANY	1.08 [55]
3	ANY	2.17 [82]
4	ANY	3.25 [110]
6	ANY	5.42 [165]

Ø 7/8" [22] HOLE (10-PLCS)

2 3/4" [71]

ELECTRIC HEATER RACK (OPTIONAL)

RETURN 9 1/8" [231] (HW & CW)  
2 1/2" [64] (STM & DX)

DRAIN PAN MATERIAL	SINGLE CONNECTION (STD) ①	SECONDARY CONNECTION (OPT) ②
GALVANIZED (STD)	7/8" OD COPPER	5/8" OD COPPER
STAINLESS (OPT)	3/4" MPT GALV.	1/2" MPT GALV.

CONTROL ENCLOSURE SIZES	
*SIZE DETERMINED BY SELECTED COMPONENTS*	
10 X 16 X 6	[250 X 406 X 152]
16 X 16 X 6	[406 X 406 X 152]

- NOTES:
- ALL DIMENSIONS ARE IN INCHES [mm] AND ARE +/- 1/8"
  - SEE SHEET 2 FOR SPECIFIC UNIT DIMENSIONS, OPTIONS & SPECIFICATIONS
  - \* 1 ROW SINGLE CIRCUIT COILS ARE ON THE SAME AXIS, BUT ARE 13 3/4" APART IN HEIGHT
  - PROVIDE ACCESS CLEARANCE FOR ELECTRICAL ENCLOSURE PER LOCAL AND NATIONAL ELECTRICAL CODE REQUIREMENTS.
  - IT IS RECOMMENDED TO PROVIDE 3' ACCESS ON PIPE CONNECTION SIDE.

# DIMENSIONAL DATA

## FNP PLENUM UNITS

Drawings are not to scale and are not for installation purposes.

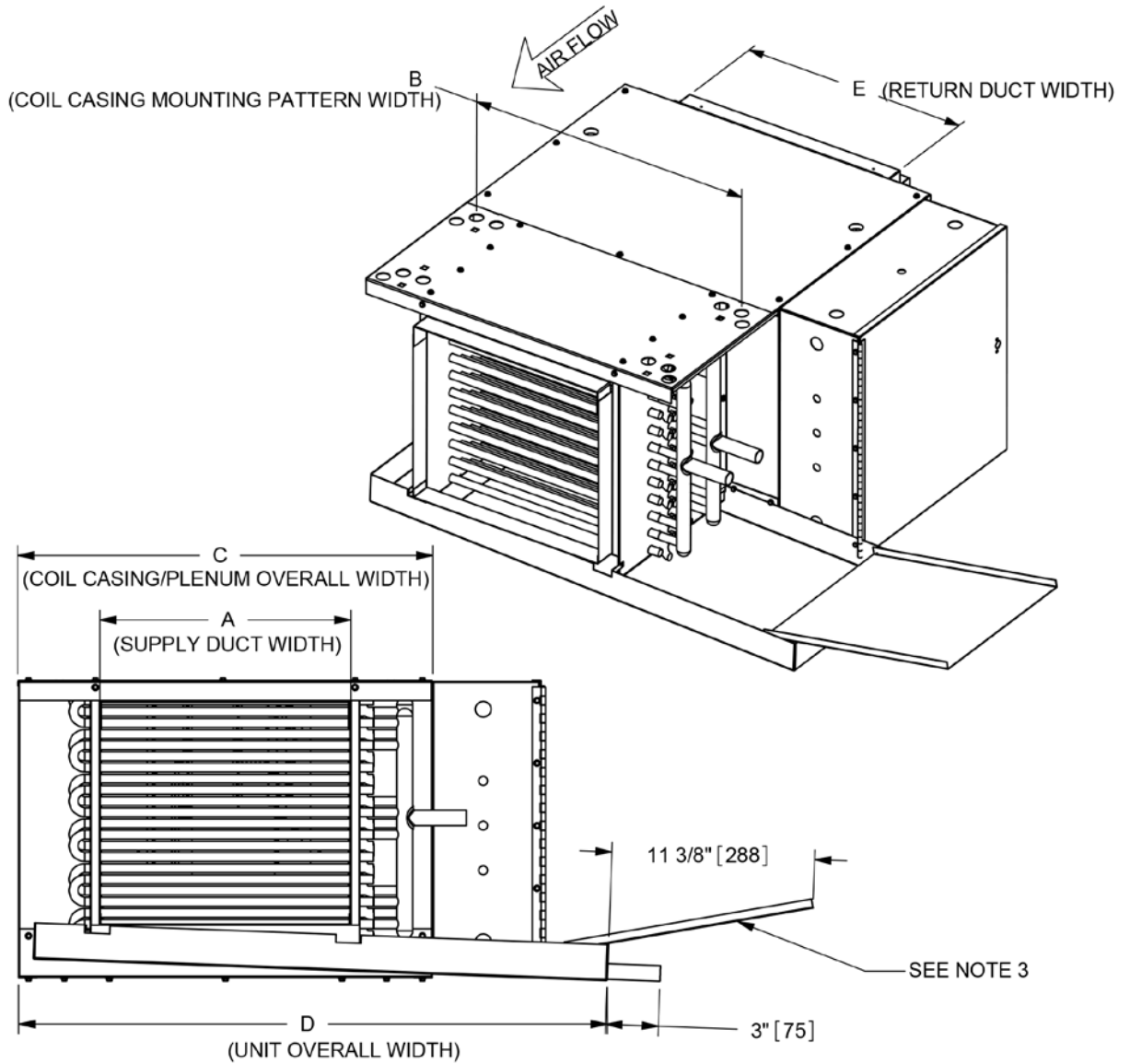

**NOTES:**

1. ALL DIMENSIONS ARE IN INCHES [mm] AND ARE +/- 1/8"
2. DRAIN PAN IS FIELD REVERSIBLE 180° AND EXTERNALLY INSULATED
3. OPTIONAL AUXILIARY DRIP PAN AVAILABLE FOR PIPING PACKAGE CONDENSATE
4. COIL HAND IS FIELD REVERSIBLE (LEFT HAND UNIT SHOWN)
5. PLENUM BOX IS FIELD REVERSIBLE FOR REAR OR BOTTOM RETURN AIR
6. FILTER RACK CAN ACCOMMODATE STANDARD 1" TAW AND 1" & 2" PLEATED FILTERS

UNIT SIZE	FAN QTY	A	B	C	D	E
06	1	14	20	23 1/8	34	16
		[356]	[508]	[587]	[864]	[406]
08	1	19	25	28 1/8	39	19 7/8
		[483]	[635]	[714]	[991]	[505]
10	1	23	29	32 1/8	43	25 7/8
		[584]	[737]	[816]	[1092]	[657]
12	2	28	34	37 1/8	48	32
		[711]	[864]	[943]	[1219]	[813]
14	2	33	39	42 1/8	53	35 7/8
		[838]	[991]	[1070]	[1346]	[911]
16	2	38	44	47 1/8	58	39 7/8
		[965]	[1118]	[1197]	[1473]	[1013]
18	2	43	49	52 1/8	63	44 7/8
		[1092]	[1245]	[1324]	[1600]	[1140]
20	2	47	53	56 1/8	67	49 7/8
		[1194]	[1346]	[1426]	[1702]	[1267]

# DIMENSIONAL DATA

## FNP WITH MIXING BOX

Drawings are not to scale and are not for installation purposes.

Unit Size	A	B	C	D
06	23 1/8 [587]	20 [508]	12 5/8 [321]	14 [356]
08	28 1/8 [714]	25 [635]	16 5/8 [422]	19 [483]
10	32 1/8 [816]	29 [737]	20 5/8 [524]	23 [584]
12	37 1/8 [943]	34 [864]	24 5/8 [625]	28 [711]
14	42 1/8 [1070]	39 [991]	28 5/8 [727]	33 [838]
16	47 1/8 [1197]	44 [1118]	32 5/8 [829]	38 [965]
18	52 1/8 [1324]	49 [1245]	36 5/8 [930]	43 [1092]
20	56 1/8 [1426]	53 [1346]	40 5/8 [1032]	47 [1194]

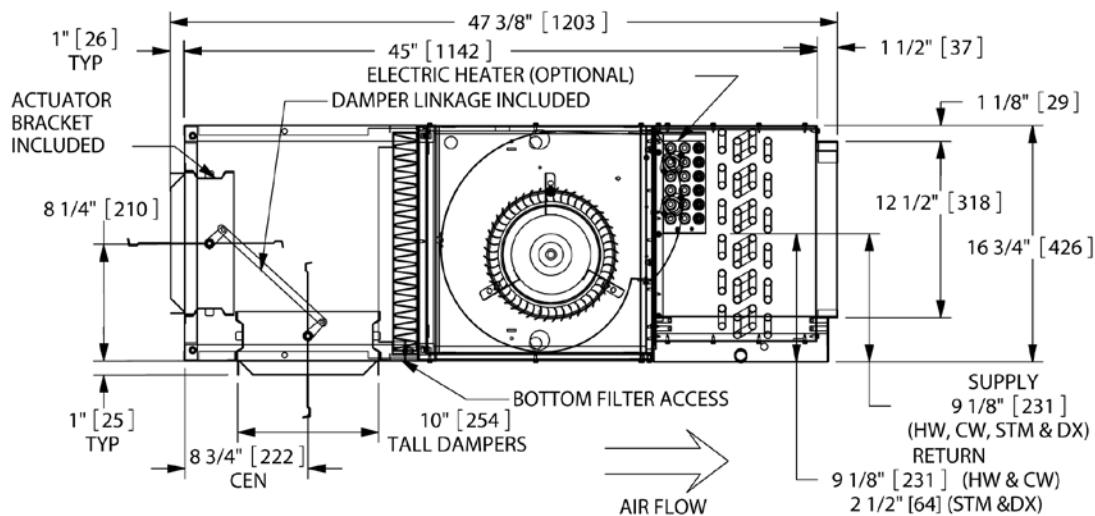
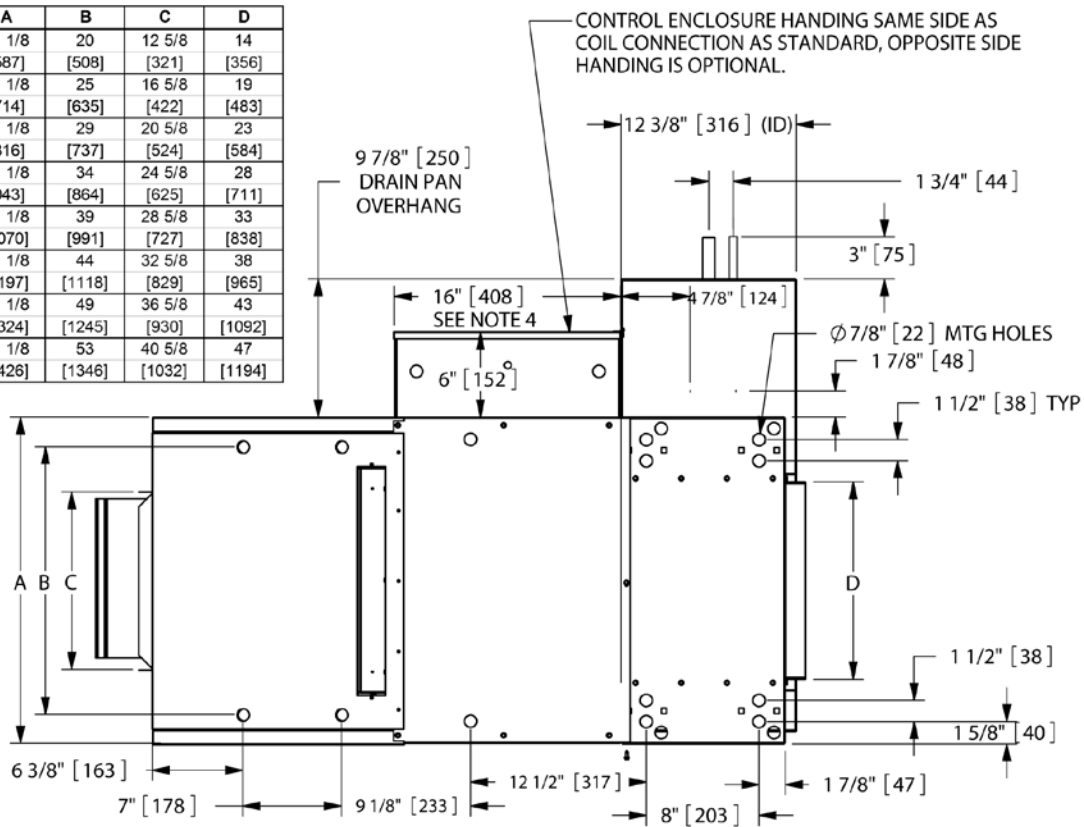

CONTROL ENCLOSURE SIZES	
*SIZE DETERMINED BY SELECTED COMPONENTS*	
10 X 16 X 6	[250 X 406 X 152]
16 X 16 X 6	[406 X 406 X 152]

- NOTES:
1. ALL DIMENSIONS ARE IN INCHES [mm] AND ARE +/- 1/8"
  2. SEE FNP SUBMITTAL FOR ADDITIONAL HP SERIES PRODUCT DIMENSIONS NOT SHOWN
  3. THE MIXING BOX IS FIELD REVERSIBLE FROM BOTTOM & REAR TO TOP & REAR RETURN
  4. PROVIDE MINIMUM 36" ACCESS CLEARANCE FOR ELECTRICAL ENCLOSURE PER LOCAL AND NATIONAL ELECTRICAL CODE REQUIREMENTS.
  5. IT IS RECOMMENDED TO PROVIDE 3" ACCESS ON PIPE CONNECTION SIDE.



# DIMENSIONAL DATA

## FNX EXPOSED CABINET UNITS

Drawings are not to scale and are not for installation purposes.

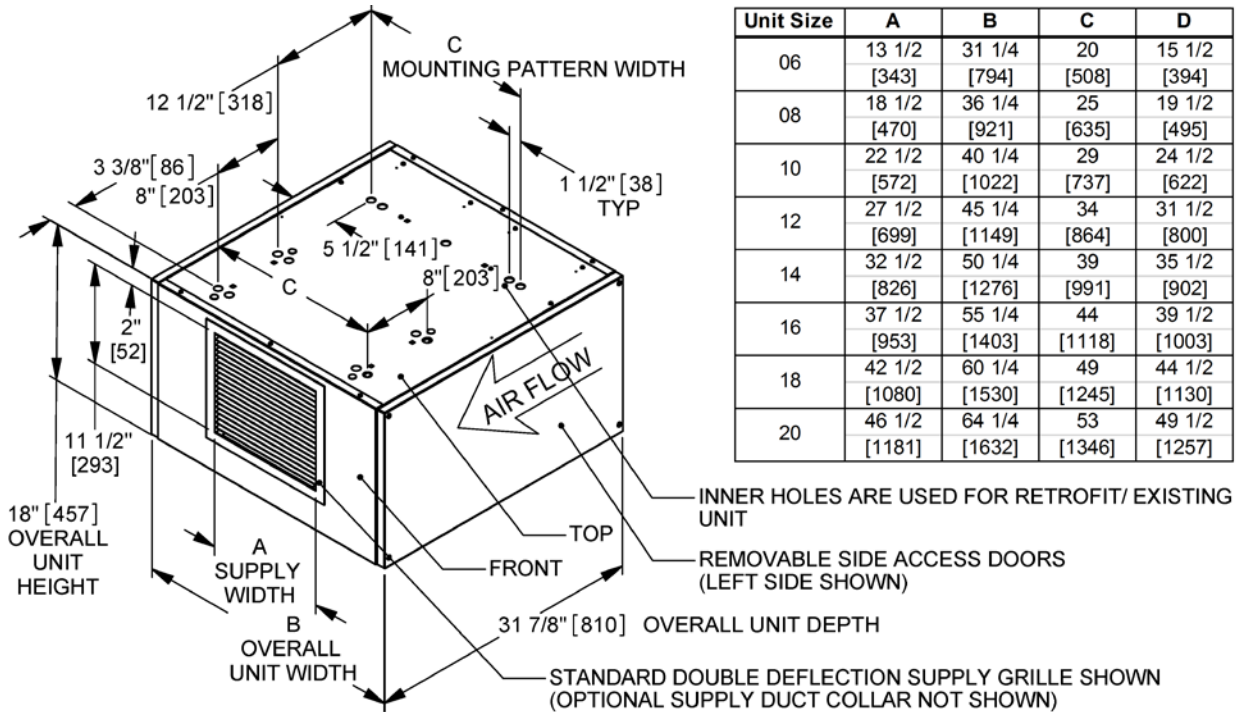

Unit Size	A	B	C	D
06	13 1/2 [343]	31 1/4 [794]	20 [508]	15 1/2 [394]
08	18 1/2 [470]	36 1/4 [921]	25 [635]	19 1/2 [495]
10	22 1/2 [572]	40 1/4 [1022]	29 [737]	24 1/2 [622]
12	27 1/2 [699]	45 1/4 [1149]	34 [864]	31 1/2 [800]
14	32 1/2 [826]	50 1/4 [1276]	39 [991]	35 1/2 [902]
16	37 1/2 [953]	55 1/4 [1403]	44 [1118]	39 1/2 [1003]
18	42 1/2 [1080]	60 1/4 [1530]	49 [1245]	44 1/2 [1130]
20	46 1/2 [1181]	64 1/4 [1632]	53 [1346]	49 1/2 [1257]

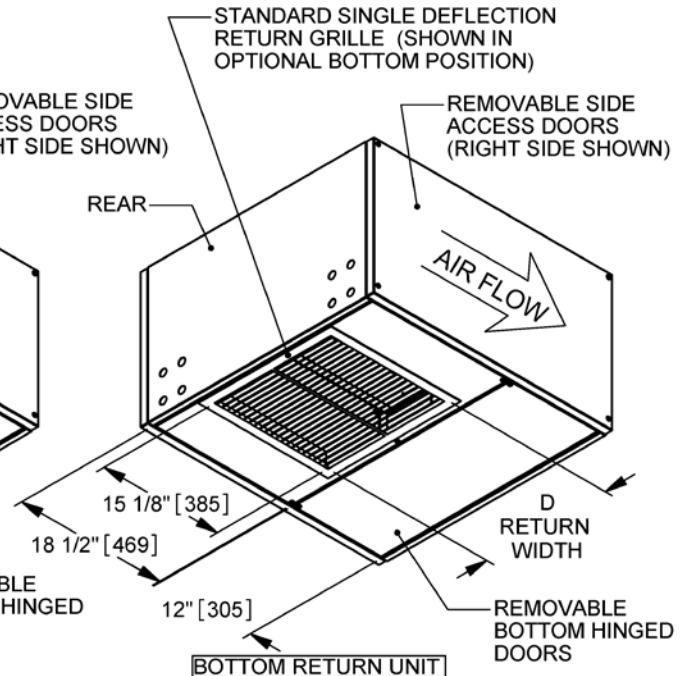
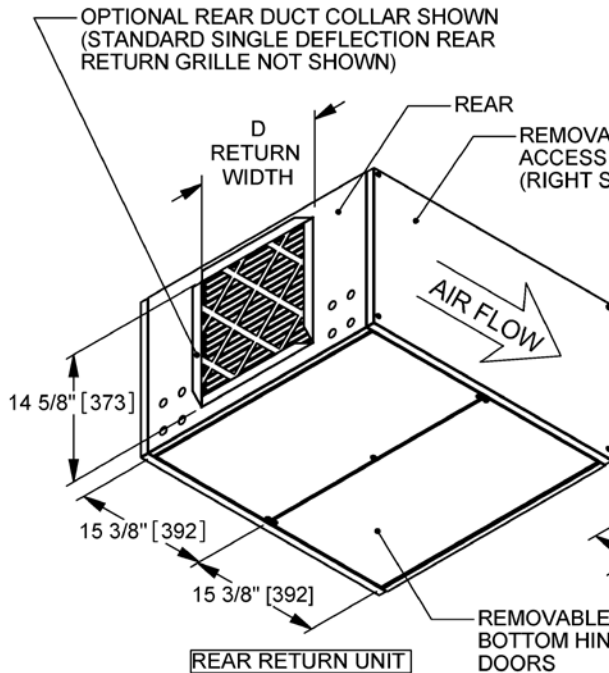

- NOTES:**
1. ALL DIMENSIONS ARE IN INCHES [mm] AND ARE +/- 1/8"
  2. SEE FNF SUBMITTAL FOR ADDITIONAL FN SERIES PRODUCT DIMENSIONS NOT SHOWN
  3. INTERNAL HINGED ELECTRICAL ENCLOSURE NOT SHOWN
  4. OPTIONAL 1" OR 2" PLEATED FILTERS AVAILABLE (SHOWN) STANDARD 1" THROWAWAY FILTER NOT SHOWN
  5. 1-1/4" DUCT COLLAR STANDARD ON ALL DUCTED UNITS
  6. PROVIDE ACCESS CLEARANCE FOR ELECTRICAL ENCLOSURE PER LOCAL AND NATIONAL ELECTRICAL CODE REQUIREMENTS (MIN. 36 INCHES).
  7. IT IS RECOMMENDED TO PROVIDE 3' ACCESS ON PIPE CONNECTION SIDE.
  8. CONTROL ENCLOSURE HANDLING IS ON THE OPPOSITE SIDE OF THE COIL CONNECTION.

INTERNAL CONTROL ENCLOSURE SIZES	
SIZE DETERMINED BY SELECTED COMPONENTS	
10 X 16 X 6	[250 X 406 X 152]
10 X 20 X 6	[250 X 500 X 152]



# DIMENSIONAL DATA

## FN TELESCOPING / FILTER AND SOLID BOTTOM ACCESS PANELS

Drawings are not to scale and are not for installation purposes.

UNIT SIZE	"A"		"B"		"C"		"D"		RECOMMENDED CEILING CUT-OUT	
	in	mm	in	mm	in	mm	in	mm	in	mm
06	48	[1219]	45 7/8	[1164]	16	[408]	15 7/8	[404]	46 1/8 X 36 1/8	[1171 X 918]
08	53	[1346]	50 7/8	[1291]	20	[509]	19 7/8	[506]	51 1/8 X 36 1/8	[1298 X 918]
10	57	[1448]	54 7/8	[1392]	25	[636]	24 7/8	[633]	55 1/8 X 36 1/8	[1400 X 918]
12	62	[1575]	59 7/8	[1519]	32	[814]	31 7/8	[811]	60 1/8 X 36 1/8	[1527 X 918]
14	67	[1702]	64 7/8	[1646]	36	[916]	35 7/8	[912]	65 1/8 X 36 1/8	[1654 X 918]
16	72	[1829]	69 7/8	[1773]	40	[1017]	39 7/8	[1014]	70 1/8 X 36 1/8	[1781 X 918]
18	77	[1956]	74 7/8	[1900]	45	[1144]	44 7/8	[1141]	75 1/8 X 36 1/8	[1908 X 918]
20	81	[2057]	78 7/8	[2002]	50	[1271]	49 7/8	[1268]	79 1/8 X 36 1/8	[2009 X 918]

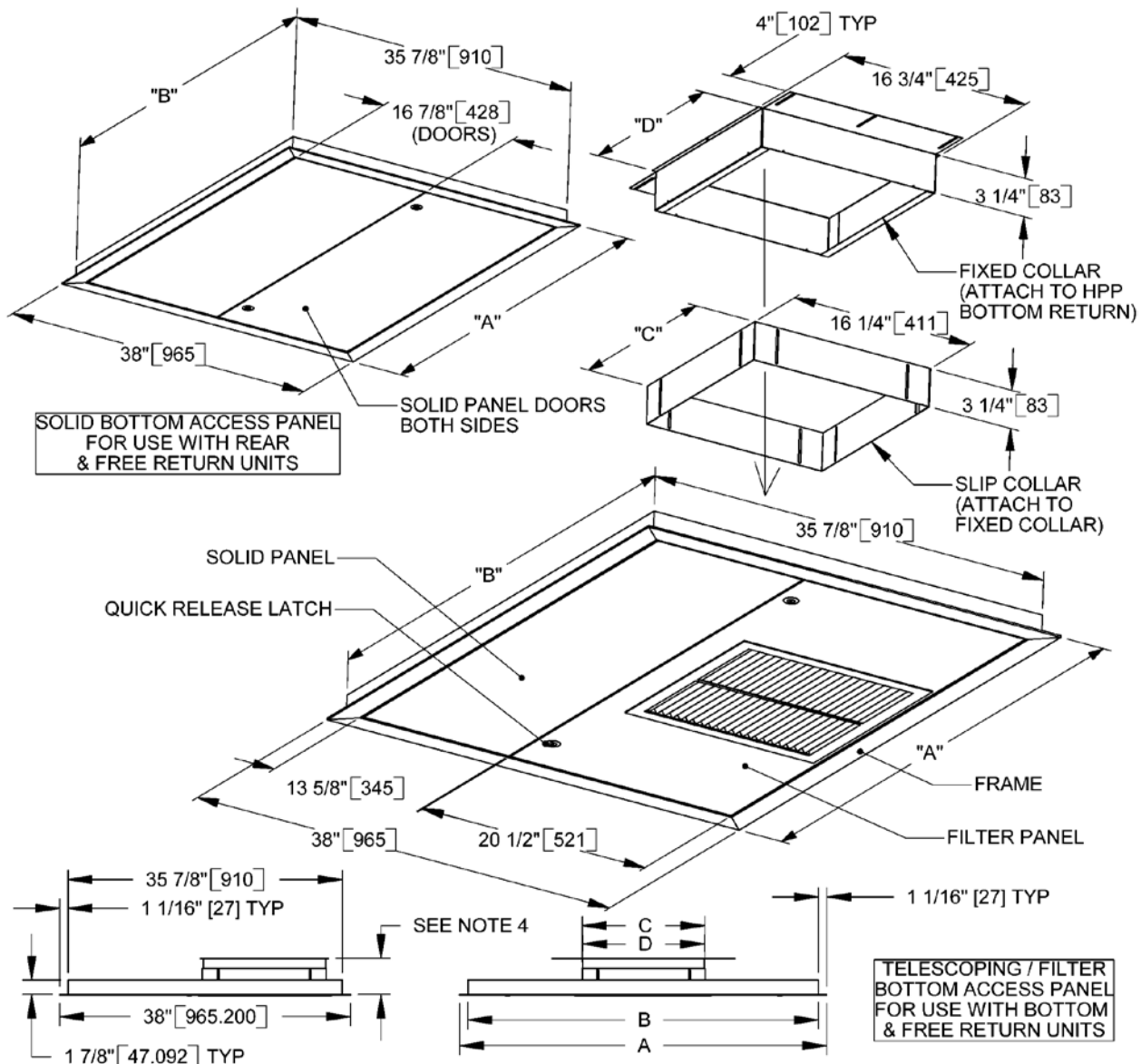

**NOTES:**

1. ALL DIMENSIONS ARE IN INCHES [mm] AND ARE +/- 1/8"
2. 1" TAW FILTER STANDARD. 1" OR 2" PLEATED FILTERS ARE OPTIONAL
3. BOTTOM PANELS ARE REMOVABLE
4. TOTAL TELESCOPING ADJUSTMENT IS 3 1/2" TO 6 1/2"
5. FILTER AND GRILLE SIZES ARE THE SAME FOR FOR EACH UNIT SIZE IN THE FN PRODUCT LINE

## GUIDE SPECIFICATIONS

### GENERAL

Furnish and install Johnson Controls Model FN Horizontal Concealed Direct Drive Fan Coil Units where indicated on the plans and in the specifications. Units shall be completely factory assembled, tested and shipped as one piece. All units shall be capable of meeting or exceeding the scheduled capacities for cooling, heating and air delivery. All unit dimensions for each model and size shall be considered maximums. Units shall be ETL listed in compliance with UL/ANSI Standard 1995, and be certified as complying with the latest edition of AHRI Standard 440.

### CONSTRUCTION

All unit chassis shall be fabricated of heavy gauge galvanized steel panels. All exterior panels shall be insulated with 1/2" thick fiberglass insulation with a maximum k value of .24 (BTU • in) / (hr • ft<sup>2</sup> • °F) and rated for a maximum air velocity of 5000 f.p.m. Insulation must meet all requirements of ASTM C1071 (including C665), UL 181 for erosion, and carry a 25/50 rating for flame spread/smoke developed per ASTM E-84, UL 723 and NFPA 90A.

**Option:** Provide foil-faced insulation in lieu of standard. Foil insulation shall meet or exceed the requirements stated above, and in addition meet ASTM Standards C-665 and C-1136 for biological growth in insulation. Insulation shall be lined with aluminum foil, fiberglass scrim reinforcement, and 30 pound kraft paper laminated together with a flame resistant adhesive. All exposed edges shall be sealed to prevent any fibers from reaching the air stream.

**Option:** Provide Elastomeric Closed Cell Foam Insulation in lieu of standard. Insulation shall conform to UL 181 for erosion and NFPA 90A for fire, smoke and melting, and comply with a 25/50 Flame Spread and Smoke Developed Index per ASTM E-84 or UL 723. Additionally, insulation shall comply with Antimicrobial Performance Rating of 0, no observed growth, per ASTM G-21. Polyethylene insulation is not acceptable.

All concealed units shall have a minimum 1 1/4" duct collar on the discharge. Plenum units shall have a minimum 1" duct collar on the return.

**Option:** For concealed units, provide a hinged bottom access panel either solid or with bottom return single deflection grille. A telescoping plenum section is available with bottom return option.

All exposed units shall have exterior panels fabricated of galvanized steel.

**Option:** For exposed units, the side and bottom access panels shall be attached with quick open fasteners to allow for easy removal and access for service.

**Option:** For exposed units, provide double deflection discharge grille and either a rear return or bottom return single deflection grille, powder coat painted to match unit color. Supply and return duct connections are available.

Unit mounting shall be by hanger holes provided at a minimum of four locations.

### SOUND

Units shall have published sound power level data tested in accordance with AHRI Standard 260-01.

### FAN ASSEMBLY

Unit fan shall be a dynamically balanced, forwardly curved, DWDI centrifugal type constructed of 18 gauge zinc coated galvanized steel for corrosion resistance. Motors shall be high efficiency, permanently lubricated sleeve bearing, permanent split-capacitor type with UL and CSA listed automatic reset thermal overload protection and three separate horsepower taps. Single speed motors are not acceptable.

The fan assembly shall be easily removable for servicing the motor and blower at, or away from the unit. The entire fan assembly shall be able to come out of the unit by removing four nuts per fan and unplugging the motor(s). Plenum unit fan assemblies shall be easily serviced through the filter opening or through the bottom panel.

**Option:** Provide an electronic (SCR) fan speed controller as an aid in balancing the fan capacity. The speed controller shall have a turn down stop to prevent the possibility of harming the motor bearings, and incorporate electrical noise suppression to minimize noise on the incoming power lines. The SCR fan speed controller is only available for high speed setting.

**Option:** Provide Electronically Commutated (EC) Motor capable of operation with 3 speed thermostat.

**Option:** Provide Electronically Commutated (EC) Motor capable of operation with 3 speed thermostat. Each speed shall be manually adjustable in the field. All manual speed adjustments shall be stored in non-volatile memory.

**Option:** Provide Electronically Commutated (EC) Motor capable of variable speed operation. Motor shall be capable of accepting a 2-10 VDC output from BAS.

### COILS

All coils shall be AHRI 410 certified and tagged with an AHRI 410 label.

All cooling and heating coils shall optimize rows and fins per inch to meet the specified capacity. Coils shall have seamless copper tubes and shall be mechanically expanded to provide an efficient, permanent bond between the tube and fin. Coil tubes shall be 3/8" outside diameter with .012" tube wall thickness. Fins shall have high efficiency aluminum surface optimized for heat transfer, air pressure drop and carryover.

All coils shall be hydrostatically tested at 450 PSIG air pressure under water, and rated for a maximum of 300 PSIG working pressure at 200°F.

Direct expansion cooling coils shall include a fixed orifice distributor. All evaporator coils shall be factory sealed and charged with a minimum 5 PSIG nitrogen or refrigerated dry air.

Steam coils shall be standard steam type suitable for temperatures above 35°F and 15 PSIG maximum working pressure.

All coils shall be provided with a manual air vent fitting to allow for coil venting.

**Option:** Provide coil tubes with 1/2" outside diameter and .016" tube wall thickness.

**Option:** Provide coil tubes with 1/2" outside diameter and .025" tube wall thickness.

**Option:** Provide automatic air vents in lieu of manual air vents.

# GUIDE SPECIFICATIONS

Cooling and heating coils shall be in a common tube sheet. Water coils on concealed models shall be field reversible for right or left hand connections.

Heating coils shall be furnished in the reheat or preheat position.

## DRAIN PANS

Primary condensate drain pans shall be single wall; heavy gauge galvanized steel for corrosion resistance, and extend under the entire cooling coil. Drain pans shall be of one-piece construction and be double sloped for condensate removal. Drain pans shall be field reversible for right or left hand connections.

The drain pan shall be externally insulated with a fire retardant, closed cell foam insulation. The insulation shall carry no more than a 25/50 Flame Spread and Smoke Developed Rating per ASTM E-84 and UL 723 and an Antimicrobial Performance Rating of 0, no observed growth, per ASTM G-21.

**Option:** Provide a single wall primary drain pan constructed entirely of heavy gauge stainless steel for superior corrosion resistance. Stainless steel drain pans shall be externally insulated and meet or exceed the requirements stated above.

**Option:** Provide a secondary drain connection on the primary drain pan for condensate overflow.

**Option:** Provide a condensate overflow switch in the primary drain pan for condensate overflow.

## FILTERS

All plenum and exposed units shall be furnished with a minimum 1" nominal glass fiber throwaway filter. Filters shall be tight fitting to prevent air bypass. Plenum and exposed unit filters shall be easily removable from the bottom of the unit without the need for tools.

**Option:** Provide unit with 1" or 2" pleated filters rated at 25-30% efficiency and MERV 6 based on ASHRAE 52.2 - 1999.

## MIXING BOX SECTION

Provide a fully insulated integral mixing box section with return and outside air dampers, including the interconnecting damper linkage. Mixing box section shall be shipped attached to the concealed plenum unit as an assembly.

**Option:** Factory-provided damper actuator to be mounted and wired to control enclosure.

## ELECTRICAL

Units shall be furnished with single point power connection. Provide an electrical junction box with terminal strip for motor and other electrical terminations. The factory mounted terminal wiring strip consists of a multiple position screw terminal block to facilitate wiring terminations for the electric control valves and thermostats.

## ELECTRIC HEAT

Furnish an electric resistance heating assembly as an integral part of the fan coil unit, with the heating capacity, voltage and kilowatts scheduled. The heater assembly shall be designed and rated for installation on the fan coil unit without the use of duct extensions or transitions, and be located in the unit as to not expose the fan assembly to excessive leaving air temperatures that could affect motor performance.

The heater and unit assembly shall be listed for zero clearance and meet all NEC requirements, and be ETL listed with the unit as an assembly in compliance with UL/ANSI Standard 1995.

All heating elements shall be open coil type Ni-Chrome wire mounted in ceramic insulators and located in an insulated heavy gauge galvanized steel housing. All elements shall terminate in a machine staked stainless steel terminal secured with stainless steel hardware for corrosion resistance. The element support brackets shall be spaced no greater than 3-1/2" on center. All internal wiring shall be rated for 105°C minimum.

All heaters shall include over temperature protection consisting of an automatic reset primary thermal limit and back up secondary thermal limit. All heaters shall be single stage unless noted otherwise on the plans.

All units with electric heat shall be provided with an incoming line power distribution block, designated to accept single point power wiring capable of carrying 125% of the calculated load current.

## PIPING PACKAGES

Provide a standard factory assembled valve piping package to consist of a 2 or 3 way, on/off, motorized electric control valve and two ball isolation valves. Control valves are piped normally closed to the coil. Maximum entering water temperature on the control valve is 200°F, and maximum close-off pressure is 40 PSIG (1/2"), 20 PSIG (3/4"), or 17 PSIG (1"). Maximum operating pressure shall be 300 PSIG.

**Option:** Provide 3-wire floating point modulating control valve (fail-in-place) in lieu of standard 2-position control valve with factory assembled valve piping package.

**Option:** Provide high pressure close-off actuators for 2-way on/off control valves. Maximum close-off pressure is 50 PSIG (1/2"), 25 PSIG (3/4"), or 20 PSIG (1").

**Option:** Provide either a fixed or adjustable flow control device for each piping package.

**Option:** Provide unions and/or pressure-temperature ports for each piping package.

Piping package shall be completely factory assembled, including interconnecting pipe, and shipped separate from the unit for field installation on the coil, so as to minimize the risk of freight damage.