

FS Fan-Coil Units Hi-Rise, Vertical

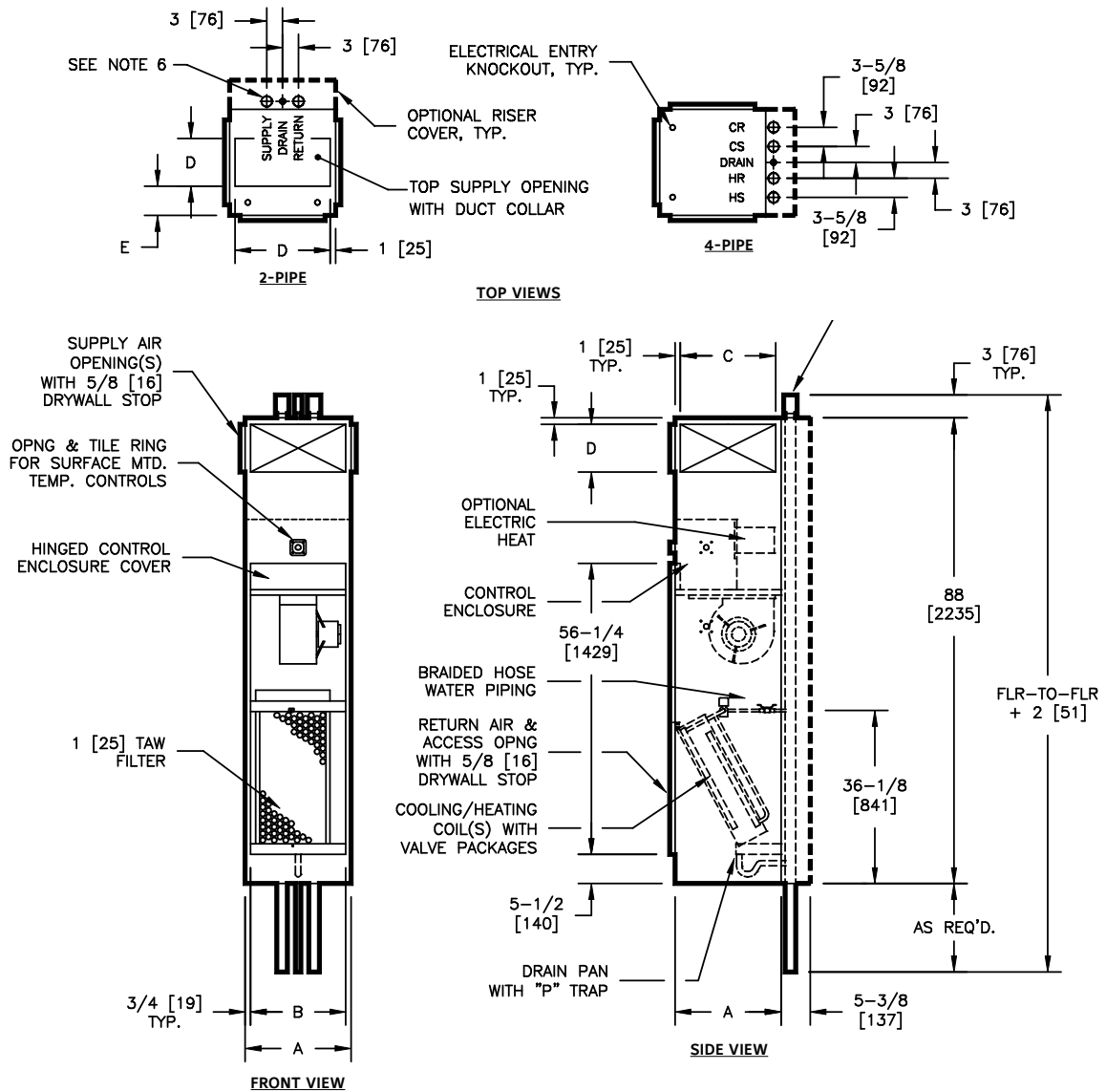

FSC Concealed Dimensional Data



Unit Size	Dimensions				
	A	B	Single/Double Supply		E
			C	D	
03 & 04	18" [457]	16 1/2" [419]	16" [406]	8" [203]	6" [152]
06 & 08	20" [508]	18 1/2" [470]	18" [457]	12" [305]	6" [152]
10 & 12	24" [610]	22 1/2" [572]	22" [559]	14" [356]	8" [203]

Notes:

- All dimensions are inches and are +/- 1/4" [6 mm]. Metric values are soft conversion.
- Tile ring is installed on front of unit as shown, and may be moved to left or right side of unit in field. Tile ring omitted on units with "ADA" control-mounting location.
- Wiring from electrical-entry point to control enclosure is furnished and installed by others in field.
- Risers available from 3/4" [19mm] to 3" [76 mm] diameter with 1/2" [13 mm] thick insulation, and 3/4" [19mm] to 2-1/2" [64 mm] diameter with 3/4" [19 mm] thick insulation.
- Riser length is 120" [3078 mm] max, 100" [2540 mm] min.
- Back riser location shown. See arrangement drawings for available unit configurations.
- Factory-mounted risers shown. Risers may also ship in advance of the unit. See ship-in-advance riser drawings for details.

Note: Drawings are not to scale and are not for installation purposes. Consult your Johnson Controls representative for current submittal drawings. All data and dimensions are subject to change without notice.

FS Fan-Coil Units: Raising the Standard in Flexibility and Performance

Owners

ARI Standard 440-certification ensures exacting performance. The FS fan-coil unit's 3-speed, direct-drive motor allows optimized cabinet airflow and sound performance. Enhanced sound levels are achieved through an electronic fan-speed controller (SCR) which allows further motor-speed fine tuning. FS fan-coil units are constructed of galvanized steel, surpassing the ASTM 125-hour, salt-spray test for corrosion and rust. Decorator front panels, supply grilles, and exposed-cabinet model FSE feature durable, powder-coat paint that resists fading, scratches and fingerprints.

Models FSA/FSB tandem units ship complete with risers enclosed in a wall plenum with one layer of 5/8" gypsum for sound attenuation. Units may be ordered with two layers of gypsum and fire-blocking material for a one-hour fire rating per UL 1479.

Concerned about Indoor Air Quality? Sloped drain pans are standard on FS fan coils. The coils are easily removed for cleaning. As an option, field-removable drain pans may be supplied. Optional stainless-steel drain pans and coil casings are available. IAQ lining options include foil-faced or elastomeric, closed-cell-foam insulation.

Designers

The FS unit's impressive list of standard features provides unparalleled design flexibility. Riser-slot knockouts are included on the left, right and back panels. Supply-air-opening knockouts are included on all sides, as well as the top of the unit. Outside air can be introduced with manual or motorized dampers.

Coil options allow for three or four-row chilled-water and one or two-row hot-water coils in the reheat position. A total of five rows of coil are accommodated.

Contractors

FS fan-coil units provide maximum performance while reducing installed cost to the contractor. Motor wiring is brought to a control compartment on the inside of the unit, reducing electrical hook-up time. Internal stainless-steel-braided hoses allow easy field-configuration of riser connections without the need for thermal cutting and joining of piping.

Risers may ship in advance of the unit to facilitate installation and fire-safing of floor penetrations in limited space. Additionally, fan-coil units are protected from construction debris during installation and pressure testing of the risers.

FS Fan-Coil Units Airflow (CFM)	
Unit Size	Nominal
03	350
04	450
06	600
08	800
10	1000
12	1200

Actual performance may vary based on model, options and operating conditions. Consult your Johnson Controls representative for complete performance information.



Factory-Mounted Control Packages

A wide variety of control options and thermostats are offered. Factory-mounting and wiring of DDC controls by others is also available.

Silent Relays

Silent, solid-state relays are available for fan and electric-heat control in sound-sensitive environments.

Factory-Furnished Valve Packages

Valve packages provided by the factory ensure proper fit, operation and performance.

Electric Heat

A variety of kW and voltage configurations are available. Options include door-interlock disconnects, low-voltage controls, and silent solid-state relays. All control and electric-heat configurations include single-point-power connection and are cETL listed as an assembly.





Fan Deck

For ease of service, the fan/motor assembly is easily removed by unscrewing two locknuts located at the front of the assembly. Slide rails support the fan during removal and installation, and the electrical harness is equipped with a quick-connect plug.



Drain Pan

The sloped, insulated drain pan is available in stainless-steel construction. Standard drain pans are externally insulated, single-wall, galvanized steel. As an option, the FS drain pan can be equipped for easy removal from the front of the unit for inspection and cleaning. For optimum moisture resistance and cleanability, the unit may be lined with foil-faced fiberglass insulation (shown above) or elastomeric, closed-cell-foam insulation.

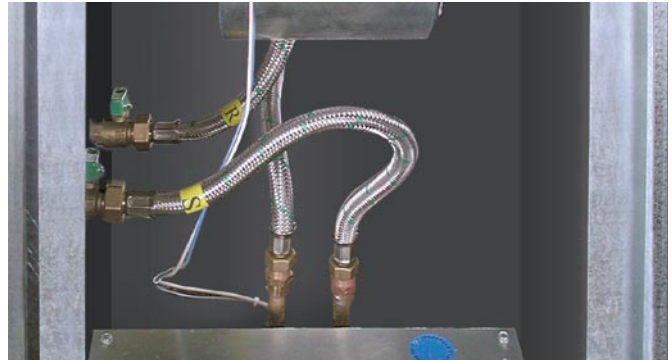

Coils And Piping

All units are available in 2-pipe or 4-pipe configurations. The heating coil is standard in the reheat position. Access for cleaning on both the entering and leaving-air sides is available. Coils are removable from the front of the unit for service.

Risers

Risers, coils and piping packages are pressure-tested and ship installed on the unit as a complete package. Risers may also ship in advance of the unit. This option greatly simplifies installation, while keeping the units free of construction debris during pressure-testing of the risers.

Filters

Filter options include 1" throwaway (standard), pleated MERV 6, or synthetic media. Filters are easily replaceable from the return air when the front panel is removed.

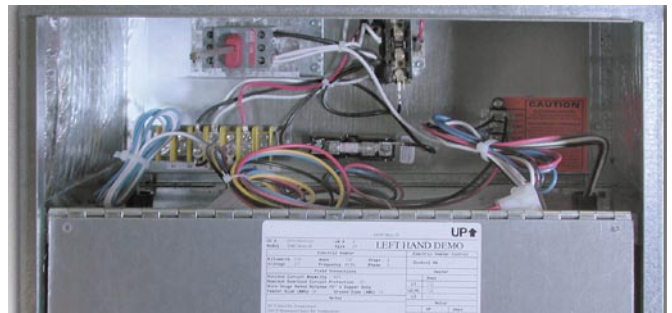

Control Enclosure

The hinged access door allows entry to a spacious electrical compartment. The compartment houses all electric-heat and control components. Terminal strips are furnished for simple power-wiring and control-wiring connections.



Field Configuration

Supply-air-opening knockouts are included on all sides, and the top, of the FS unit. Riser-slot knockouts are included on both sides, as well as the back panels. If requested, the unit ships from the factory with knockouts removed for the selected arrangement of supply air and riser location.



Stainless-Steel-Braided Hoses

Standard on all 1/2" 2-pipe and 4-pipe systems, stainless-steel-braided hose kits allow for flexibility and thermal expansion within the unit cabinet. The hose-to-coil and hose-to-riser connections are made via a threaded swivel adapter, simplifying coil removal. For more information, see the FS Hose Kit sales sheet at www.johnsoncontrols.com.

Powder-Coated Painted Surface

Exposed-cabinet model FSE, as well as the front-return, textured, decorator panel, feature a powder-coat finish that resists scuffing, scratching, fading, and fingerprints.



FS Fan-Coil Unit Features

STANDARD FEATURES:

Construction

- ARI Standard 440-certified and labeled
- Galvanized-steel construction
- 1/2" thick fiberglass insulation
- Integral filter rack with 1" throwaway filter
- Riser-slot knockouts
- Supply-air knockouts

Decorator Front Panel

- Stamped louver return-air grille
- Durable, powder-coat paint
- Quarter-turn, cam-lock fasteners

Supply Air

- Single outlet
- Front, side or top outlets

Coils

- Cooling: 3 or 4-row chilled water
- Heating: 1 or 2-row hot water – reheat position
- 5 total rows of cooling and heating coils maximum
- 1/2" O.D. seamless copper tubes
- 0.016" tube-wall thickness
- High-efficiency, aluminum-fin surface for optimizing heat transfer, pressure drop and carryover
- Easily removable for service
- Manual air vents

Drain Pans

- Single-wall, galvanized-steel, externally insulated – fire retardant and anti-microbial
- Positively sloped to drain connection
- 7/8" O.D. drain connection
- P-trap is factory-installed

Fan Assemblies

- Forward-curved, DWDI, centrifugal-type blowers
- 115-volt, single-phase, three-tap PSC motors
- Quick-disconnect motor connections
- Easily removable fan/motor deck for service

Electrical

- cETL listed for safety compliance
- Electrical enclosure with access door for field-wiring terminations
- Terminal block for field connections

Electric Heat

- ETL-listed as an assembly for safety compliance
- Integral electric-heat assembly with removable elements for easy service
- Automatic-reset primary and back-up secondary thermal limits
- Single-point-power connection

OPTIONAL FEATURES:

Construction

- Master/slave arrangements
- Foil-faced fiberglass insulation
- Elastomeric, closed-cell-foam insulation
- 1" pleated filter (MERV 6)
- Synthetic media
- Manual or motorized outside-air damper
- Blower shield

Decorator Front Panel

- Recessing frame
- Full-faced aluminum grille

Supply Air

- Double-deflection discharge grille(s)
- Double outlets
- Sight and sound baffles for double-outlet units
- Opposed-blade damper

Coils

- Automatic air vents
- 0.025" tube wall
- Stainless-steel coil casings

Drain Pans

- Stainless-steel construction with external insulation
- Removable for cleaning

Fan Assemblies

- 208-230 & 277-volt, single-phase, three-tap PSC motors

Electrical

- SCR fan-speed controller
- Fan-relay packages
- Silent, solid-state fan relays
- Toggle disconnect switch
- Condensate-overflow switch (drain pan)
- Main fusing
- Unit and remote-mounted, three-speed fan switches

Electric Heat

- Manual-reset, secondary thermal limit
- Silent relay/contactors
- Door-interlocking disconnect switches
- Main fusing

Piping Packages

- Factory-assembled and installed
- 1/2", 2-way and 3-way, normally closed, two-position, electric, motorized valves
- Stainless-steel-braided hoses (threaded swivel connections) for thermal expansion, including isolation ball valves with memory stop
- Fixed-flow and adjustable-flow control devices
- P/T ports and Y-strainers
- Modulating control valves
- High-pressure, close-off actuators (50 PSIG max)

Thermostats

- Analog, digital display, or programmable
- Unit-mounted and wall-mounted
- 2-pipe and 4-pipe control sequences
- Automatic and manual changeover
- Integral, three-speed, fan switches
- ADA mounting location on front panel or unit sides

Risers

- Type-M or Type-L copper with swaged connections
- 3/4" to 3" diameters
- 1/2" and 3/4" closed-cell insulation
- Type-M copper condensate riser
- Riser extensions
- Riser cover
- Ship-in-advance risers